

# **Public Toilets In Managed Stations**





# Document Verification

Design Guidelines  
Managed Stations WC's  
NR/GN/CIV/200/04  
Issued: October 2020  
OFFICIAL  
3/72

## Authorisation

Name	Department or Role
Anthony Dewar	Professional Head Buildings & Architecture, Technical Authority
Frank Anatole	Principal Architect Buildings & Architecture, Technical Authority

## Technical Lead

Name	Department or Role
Trevor Wilson	Senior Architect Buildings & Architecture, Technical Authority

## Developed By

Name	Department or Role
Landolt + Brown	Architects

## Revision Information

**Version:** 1.0  
**Date issued:** October 2020

**Description of changes:**  
First issue

## Disclaimer

In issuing this standard/control document for its stated purpose, Network Rail Infrastructure Limited makes no warranties, expressed or implied, that compliance with all or any standards/control documents it issues is sufficient on its own to provide safety or compliance with legislation. Users are reminded of their own duties under legislation.

Compliance with a Network Rail standard/control document does not, of itself, confer immunity from legal obligations.

Where Network Rail Infrastructure Limited has granted permission to copy extracts from Network Rail standards or control documents, Network Rail Infrastructure Limited accepts no responsibility for, nor any liability in connection with, the use of such extracts, or any claims arising there from.

This disclaimer applies to all forms of media in which extracts from Network Rail standards and control documents might be reproduced.

# Preface

## What do we mean by 'world class'?

As part of Network Rail's commitment to putting passengers first, its senior station's team set an objective to provide world class WC facilities as toilets are upgraded in Managed Stations over the next few years.

World class means many different things to different people. For some it might mean gold taps and veined marble, while for others it could be pared back minimalism where lights, taps, switches and drainage points are hidden from view and operated by a discrete wave of the hand. What seems most important is that 'world class' should be intrinsically linked to context and use. Our major stations have a very particular set of requirements; their use is unusually intense and continuous all day and well into the night. In many instances there are too few fittings and little available space to provide more, in the short-term at least. They therefore have to work exceptionally hard in the most demanding of settings where, despite best efforts to clean and monitor them, crime and antisocial behavior are an unfortunate reality. In

this context, world class is very much related to durability and robustness over time.

We therefore asked ourselves two simple questions: Firstly, we asked where have we seen outstanding public conveniences in a demanding public setting that have stood the test of time. Our team looked at many examples from across the UK and in particular we were impressed by the historic loos at the Rothesay West Pier on the Isle of Bute. Here the weighty sanitaryware, glazed brick, glistening copper pipes and robust fittings speak of timeless quality and the planted central urn is as joyful as it is unexpected.

As a more recent example we cited the Barbican loos by architects Chamberlin, Powell and Bon with their immaculately detailed terrazzo giving a sense of elegant permanence. Both are now listed for good reason. The newer loos at the V&A Members' Room by Carmody Groarke architects share many of the timeless qualities of the older, listed loos, but brought up to date with a contemporary approach to details, materials and fittings. These examples

are exactly the right sort of 'world class' Network Rail is looking for. Tough, robust, well-built, well ventilated, and all beautiful in their own way.

(continued overleaf)



Rothesay Pier Public WC's, Isle of Bute.  
Image: Mike Nettlehip



V&A Members' Room WC's by Carmody Groarke.  
Image: Rory Gardiner



The Barbican WC's by Chamberlin, Powell and Bon.  
Image: Marissa V, Flickr

# Preface

Secondly, we asked whether the railway itself had its own historic precedents that shared some of the timeless quality we see at Rothesay, the Barbican and the V&A. The answer, of course, is yes. Peckham Rye's extraordinary loos, hidden from view for decades but now lovingly restored are a case-study in beautifully detailed mosaic and glazed brick with full height cubicles, heavy doors and their own substantial porcelain and brass fittings. The loos at South End Green are no less magnificent and there is another example at Manchester Victoria; this has been modified over time but the essence of these elegant old loos is still visible. We have also seen fragments of wonderful art nouveau wall tiles in the basement at Charing Cross. No doubt more will reveal themselves over time.

There is a great deal of similarity between these examples. Several use glazed ceramic walls of one type or another – tiles, glazed brick, mosaic and in many instances wall and floor corners are curved to make them tough enough to take knocks and bumps, as well as making them easy to clean. Each one has (or at least had) weighty

sink and WC fittings, tough but elegant sanitaryware which feels 'built in' rather than 'fitted out'. Cubicles are formed out of full-height solid walls, not wafer-thin, rattling partitions, giving a sense of privacy and dignity rarely found in most modern, laminate-lined public WC's.

Our new loos need to be of today, not copies of a previous era, but there are strong clues in these tough, elegant, timeless loos which we can learn from as we develop new, sustainable, world class station facilities which put passengers first.



Top: Manchester Victoria WC's.  
Image: Network Rail

Above: South End Green WC's.  
Image: London Less Travelled,  
Flickr

Right: Original Tiling, Charing  
Cross Station. Image: Network  
Rail



Peckham Rye Station Toilets. Image: Benedict  
O'Looney Architects

# How to use this document

## Purpose

The Network Rail Design Guidance for Public Toilets in Managed Stations is intended to provide a consistent approach to design quality across the Managed Stations Portfolio.

## Scope

The intended audience for the Design Guidelines are architects, designers, project managers, project sponsors and others involved in designing WC's for Network Rail.

The Design Guidelines are contained in a single document divided over six sections:



### Section 1

Introduction and Guiding Principles

Provides a background for the need for design guidance, the document's purpose and intended audience, along with guiding principles for design development.

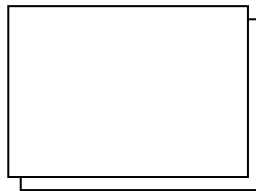

### Section 2

Capacity and User Groups

Calculating appropriate levels of provision, including the gender split and number of appliances required. Providing unisex and accessible facilities for all users.

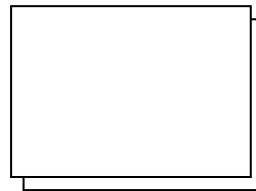

### Section 3

Space Planning Guidance for Facilities

Provides information on dimensions and layouts for key WC components, circulation and activity spaces in all types of facility.



### Section 4

Services Coordination

Strategic principles for the integration of water supply and drainage, ventilation, power, fire safety and lighting including primary servicing and maintenance routing.

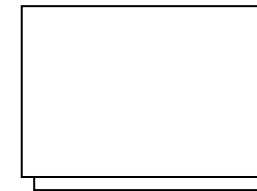

### Section 5

Wayfinding and Information

Guidelines to provide a hierarchy of signage, including logos for individual facilities, supergraphics, customer feedback tablets and wider station information.

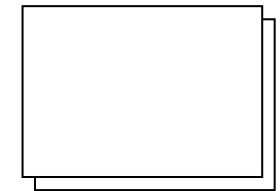

### Section 6

Materials, Fixtures, and Finishes

Preferred materials palette, lighting, planting, and a selection of appropriate fittings and finishes for key components.



Public Toilets In Managed Stations  
**Introduction and Guiding Principles**





# Introduction and Guiding Principles

## 1.1 Background

The Design Guidance for Public Toilets in Managed Stations is intended to promote a common design approach based on the principle of 'putting passengers first' across the Managed Stations portfolio.

Network Rail is in the process of updating several of its design guidance documents. As part of this, design guidance for public toilets in managed stations has been prepared in anticipation of the upgrade of such facilities at several stations in the near future.

Customer feedback clearly indicates that the quality, security and environment within station WC's is a major factor in customer satisfaction. In recent years, the move towards free-to-use WC's - whilst broadly welcomed by the travelling public - has led to a significant uplift in user numbers and changes in user behaviour, which are putting added pressure on existing facilities.

During 2019 Network Rail undertook a pilot WC upgrade project at London Victoria, based on a brief developed

with Design Council and senior Network Rail representatives. This project represents a step-change in design quality and environmental conditions within one of the UK's most heavily used stations. Customer feedback has been closely monitored since opening and has been overwhelmingly positive.

Similar upgrade projects led by the same team are currently being developed at London Bridge and London Charing Cross, providing a wider range of site conditions against which to test and refine the design approach to suit varying constraints and user patterns.

A set of guiding design principles has been established through the development of these pilot projects and important lessons have been learnt from customer and staff feedback.

There have also been long-term implications of change for station management and maintenance teams that need to be understood, communicated and managed in any future upgrade projects.

The timing is therefore ideal for the preparation of a design guide which can be used by project sponsors, project managers, designers and key stakeholders involved in WC upgrade projects in the near future.

A number of British Standards and UK Building Regulations are quoted throughout this document. Where British Standards are codes of practice, they take the form of guidance and recommendations.

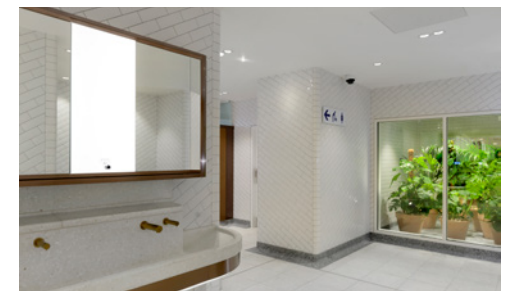

London Victoria WC's - Landolt + Brown in collaboration with artist Wendy Hardie.  
Images: Peter Langdown

# Introduction and Guiding Principles

## 1.2 Guiding Principles

### Putting Passengers First: 5 Guiding Principles of good WC Design

Initial briefing workshops with Design Council, design development for London Victoria and the careful appraisal of recent passenger and staff feedback have informed Network Rail's guiding design principles.

**Cosmetic upgrade will not enhance the customer experience if user groups are not catered for equally, if air quality is poor, maintenance is inadequate, or if the design is not robust enough to cope with the intensity of use.**

Construction regularly requires the closure and temporary relocation of WC facilities. This is costly and customer feedback is consistently negative. Consideration of extended design life is therefore essential in achieving long-term value.

#### Dignity

Treating customers with dignity has a major impact on customer satisfaction and presents Network Rail as a considerate, customer-focussed organisation. Good design should consider:

- Adequate capacity for all user groups
- An appropriate gender balance
- Generous spatial standards
- Suitable levels of privacy
- Good air quality, drainage capacity and well designed lighting
- Customer feedback systems

#### Safety

Safety is fundamental to good design. The removal of turnstiles is leading to increased antisocial and drug-related behaviours, and terror threats are high. Good design should consider:

- Terrorism threats
- The risk of concealed drugs and weapons
- Emergency services access
- The appropriate use of CCTV, good lighting and the avoidance of blind spots
- Visible CCTV monitoring
- A robust fire safety strategy

#### Resilience

Managed Station WC's have abnormally high user numbers and a wide range of users. Designs must be robust, easy to maintain and have a long design life. Good design should incorporate:

- Hard-wearing, easily cleaned and vandal resistant materials, fixtures and fittings
- Good maintenance access, provided within dedicated service zones where possible
- Construction detailing which minimises cleaning and maintenance

#### Accessibility

Network Rail should be seen as an exemplar organisation in terms of fully accessible facilities that consider all user groups and encourages diversity and inclusion. Good design should include:

- Excellent wayfinding with clear, intuitive circulation routes
- Fully accessible facilities
- Gender neutral facilities
- Excellent facilities for children and childcare
- Changing Places toilets where possible for those requiring a high level of assisted care

#### Sustainability

Network Rail is committed to reducing carbon emissions and minimising the consumption of natural resources. Good design should consider sustainability from the outset and include:

- Materials which minimise embodied carbon
- Fittings which minimise water and detergent consumption
- Low energy lighting sources
- Exclusion of CFC's and formaldehyde
- Selection of materials from sustainable sources

Public Toilets In Managed Stations  
**Capacity and User Groups**



# Capacity and User Groups

## 2.1 User Groups

### 2.1.1 Diversity Impact Assessment

A Network Rail's Diversity Impact Assessment (DIA) should be undertaken on an individual project basis to give due consideration to all user groups.<sup>[1a]</sup>

### 2.1.2 Men and Women

Women require a higher level of public toilet provision than men, as they require longer to use the toilet, and have more reasons to use the toilet. <sup>[1b]</sup>

Women require twice as many appliances as men to achieve equal waiting time (see section 2.2), and have historically been under-provided with toilets, therefore it should not be assumed that existing facilities for women are adequate in terms of quantity.

When calculating the numbers of appliances required, one urinal should be counted as equivalent to one WC.

### 2.1.3 Children and Babies

Unisex baby-changing facilities should be provided, however, it is also advantageous to provide baby-changing facilities within separate-sex areas. This can be achieved using:

A) Family Toilet. Enabling a parent or carer, young child and baby to all use the same facility, a family toilet should contain a screened WC, washbasin and baby-changing unit with adjacent toddler seat. The inclusion of an additional, smaller, WC for children should be considered where space allows. The cubicle and door should be large enough to accommodate a double pushchair (see section 3.6).

B) An enlarged toilet cubicle that can incorporate a baby changing unit, and can also be used by people who need more space and by people with luggage (see section 3.5).

Additional baby-changing options are described in BS6465-4:2010, 10.2.3.

### 2.1.4 Persons with disabilities and persons of reduced mobility (PRMs)

'Persons with disabilities and persons of reduced mobility' means any person who has a permanent or temporary physical, mental, intellectual or sensory impairment which, in interaction with various barriers, may hinder their full and effective use of transport on an

equal basis with other passengers, or whose mobility when using transport is reduced due to age.<sup>[1c]</sup>

With the increased mobility of disabled people and the UK's ageing population, public toilets should contain accessible provision as described on page 16. This should include Changing Places toilets at larger stations.

In areas such as stations, where people are likely to be carrying luggage, step-free access, additional circulation space and larger cubicle sizes should all be considered.

### 2.1.5 Gender Neutral see section 3.13

### 2.1.6 Multi-Faith Facilities

Sanitary accommodation respecting religious and faith sensitivities should be provided for where applicable, however, the design and specification of such accommodation is beyond the scope of this document. It is necessary to obtain specialist advice for such

facilities. Contact:  
[multifaith@networkrail.co.uk](mailto:multifaith@networkrail.co.uk)



Louis Hellman, *Queuing for the ladies*, 1992, cartoon first published in *Access by Design*, accessed February 17, 2020, [www.louishellman.co.uk](http://www.louishellman.co.uk)

1a. Under the Equality Act a DIA is the tool used by Network Rail to demonstrate its Public Sector Equality Duty responsibilities are met.

1b. *Invisible Women- Gender neutral with urinals.* Caroline Criado Perez

1c. *Commission Regulation (EU) No 1300/2014 (PRM TSI), 2.2 - Definition of 'person with disabilities and person with reduced mobility'*

# Capacity and User Groups

## 2.2 Calculating Provision

The levels of WC provision required will be affected by several factors across stations; the calculations shown here are indicative only and WC provision should be considered on an individual station basis.

Network Rail's recommends that 1 unit (WC/urinal) be provided per 2500 - 3000 passengers of daily throughput.

Therefore, the recommended method for calculating provision is as follows:

**AM 3 hour peak x 4 = Daily peak Daily peak / 3000 = Total units required**

The 'AM 3 hour peak' is the total number of passenger entries/exits on a typical weekday between 07:00 - 09:59.

The average time a person takes to use the facilities should be taken as 1.5 minutes for women and 0.75 minutes for men.<sup>[2]</sup> Therefore, assuming an equal number of male and female users, there should be twice as many female units

provided as male units.

To calculate the provision required for female/male WC's:

**Total units required x 2/3 = Female Units**  
**Total units required x 1/3 = Male Units**

These calculations are only for the provision of separate-sex facilities; unisex facilities should be provided in addition to the calculated 'total units required' (see section 2.4).

Further guidance on calculating provision is available within BS6465-4:2010, and BS6465-1:2006.

### Example

Liverpool Street Station

AM 3 hour peak arrivals and departures = 79,687 (2017)  
79,687 x 4 = 318,748 daily peak  
318,478 / 3000 = 106 total units

106 x 2/3 = **71 female units**  
106 x 1/3 = **35 male units**

WC counts at three London stations show a pattern in WC usage on a typical weekday, with two peaks at 11:00 - 12:00 and 18:00 - 19:00. WC's are more frequently visited in the PM peak, despite greater passenger numbers in the AM peak.

Counts over a one week duration show that patterns of usage vary depending on the location of each station. Stations serving financial districts see highest WC usage on a Friday, with significantly less usage on weekends. Stations with a greater proportion of leisure travellers see a gradual increase in WC usage throughout the week, with highest WC usage on a Saturday.

The quantity of separate-sex WC's and the gender split should be considered on an individual station basis. In certain circumstances the level of provision for each gender may need to be varied to accommodate passenger demographics, particularly in stations where there are both significantly more male customers during the week, and a significant decrease in passenger numbers at the weekend (e.g. London Cannon Street).

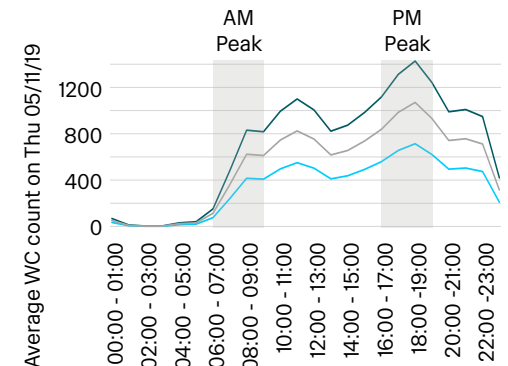

Fig. 01 - Hourly Variation in WC Usage

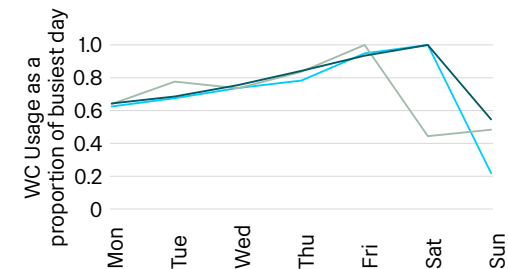

Fig. 02 - Daily Variation in WC Usage

Key:

- London Waterloo
- London Charing Cross
- London Cannon Street

2. BS6465-4:2010, 11.2.3.4.3 Time a person takes to use the facilities

# Capacity and User Groups

## 2.3 Calculating Provision (Alternative Method)

An alternative method for calculating WC provision can be found in BS6465-4:2010. This equation is used to determine provision in all public environments and is not specific to rail stations, therefore **it is recommended to use the Network Rail method as described on the previous page**. The level of provision in stations should always exceed the requirements as calculated using the below method.

$$N = (U \times A \times T) / P$$

N = Total units

U = Total potential users

A = Arrival rate, i.e. the percentage (as a decimal fraction) of the number of potential users (U) likely to use the WC's in a given period (P);

T is the time a person takes to use the facilities (in minutes);

P is the period of time used for measurement (in minutes).

The number of units required for male and female WC's should be calculated separately as T (time a person takes to use the facility) is 0.75 minutes for men and 1.5 minutes for women.<sup>[3]</sup>

3. BS6465-4:2010, 11.2.3.4.3 Time a person takes to use the facilities

Extrapolating figures on WC usage over a one week period gives an approximate number of users for a year, and a corresponding average arrival rate (i.e. the percentage of the number of potential users likely to use the WC's).

London Waterloo: 6.5%

London Charing Cross: 8.1%

London Cannon Street: 4.4%

Following the upgrade to the WC's at London Victoria, the arrival rate has increased significantly as customer perceptions of the WC's improve. For the purposes of calculation, the arrival rate in stations is assumed to be 9%.

Fig. 04 shows that WC usage at London Waterloo is 50% greater amongst men than women during the week, with equal numbers of men and women using WC's at the weekend.

For the purposes of calculation, it is assumed that equal numbers of men and women will require use of the WC's.

Stations serving long distance destinations are likely to see longer dwell times, and an increased demand

### Example

Liverpool Street Station

AM 1 hour peak arrivals and departures = 37,319 (2017)

$U = 37,319 / 2 = 18,660$

A = 9%

T = 0.75 or 1.5 minutes

P = 60 minutes

**Female Units:**

$(18,660 \times 0.09 \times 1.5) / 60 = 42$

**Male Units:**

$(18,660 \times 0.09 \times 0.75) / 60 = 21$

for WC's. Non-travellers using the station (up to a third of station users in some instances) should be considered.

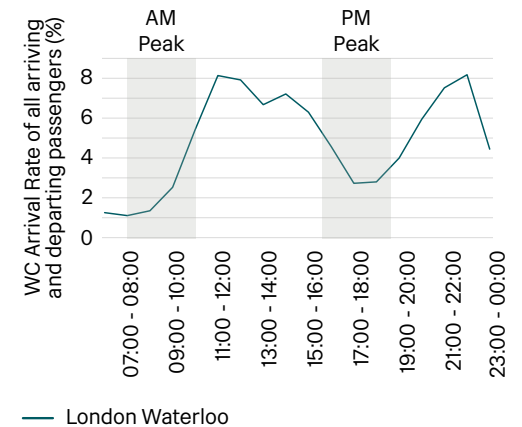

Fig. 03 - Hourly Variation in Arrival Rate

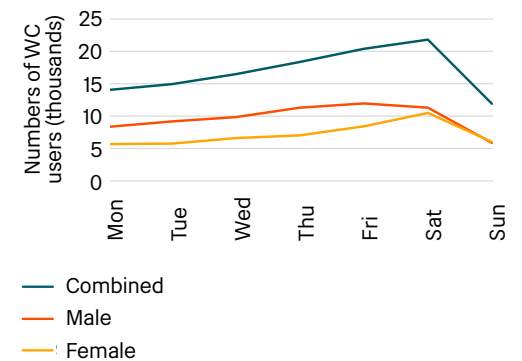

Fig. 04 - WC Usage by Gender - London Waterloo

# Capacity and User Groups

## 2.4 Quantity of appliances required

In general, one urinal should be counted as equivalent to one WC when calculating the numbers of appliances required. The following refers only to the quantity of appliances within separate-sex facilities.

When calculating the number of appliances required in male facilities, every male toilet should have at least one WC, and at least one WC per 4 urinals or part thereof.<sup>[4]</sup>

To determine the number of WC's and urinals required:

**Total units required / 5 = WC's required (round up to integer)**

**Total units - WC's = Urinals required**

It is recommended to provide one washbasin for every WC, however, where space is particularly constrained, it is acceptable to provide one washbasin for every two WC's (Fig. 05).<sup>[5]</sup>

A minimum of one washbasin should be provided for every five urinals (Fig. 06).<sup>[5]</sup>

Where two or more washbasins are provided, at least one washbasin (and soap dispenser if separate) with its rim between 720 mm and 750 mm above finished floor level should be provided for use by children and people of short stature (Fig 05).<sup>[6]</sup> Additionally, a minimum of one urinal should be fitted at low level for children and people of short stature (Fig. 06).<sup>[7]</sup>

Where there are four or more WC cubicles in separate-sex toilet accommodation, one of these should be an enlarged cubicle (1200 mm minimum width) for use by people who need extra space (Fig 05).<sup>[8]</sup>

Requirements for cubicles, urinals and washbasins for wheelchair users and people with ambulant mobility impairments are described overleaf.

Guidance on space planning for separate-sex cubicles, urinals and washbasins can be found in Section 3 of this document.

### Example

Prior calculations (see page 12) determined 35 male units and 71 female units required.

#### Male Units:

35 (Total) / 5 = **7 WC's**

35 (Total) - 7 WC's = **28 urinals**

Male Washbasins:

7 WC's / 2 = 3.5 → 4 min.

28 Urinals / 5 = 5.6 → 6 min.

4 + 6 = **Min. 10 washbasins**

#### Female Units:

71 Total = **71 WC's**

Female Washbasins:

71 WC's / 2 = 35.5 → = **Min. 36 washbasins**

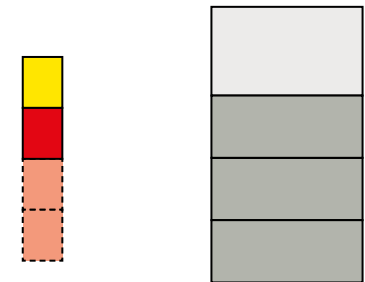

Fig. 05

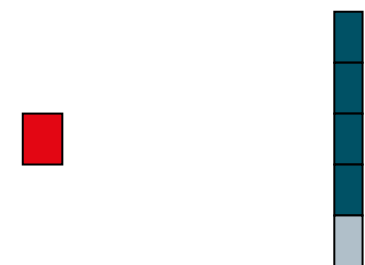
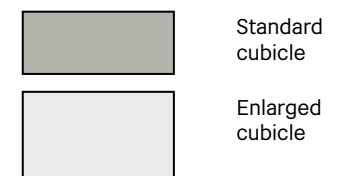
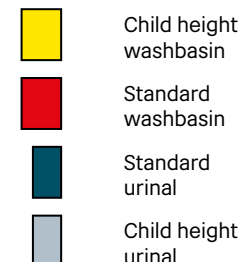

Fig. 06

Key



4. BS6465-4:2010, 10.1.3 Men and women  
5. BS6465-4:2010, 19.10.1.1 Hand washing

6. BS6465-4:2010, 19.10.1.3 Hand washing  
7. BS6465-1:2006, 5.3.2.9 General provisions  
8. BS6465-4:2010, 10.3.2 Disabled people

# Capacity and User Groups

## 2.4 Quantity of appliances required (continued)

Separate-sex facilities should provide WC's, urinals, and washbasins accessible to people with ambulant mobility impairments. Where applicable, male facilities should also provide urinals and washbasins accessible to wheelchair users.

Accessible WC compartments for people with ambulant mobility impairments, often referred to as 'ambulant cubicles', should make up 10% of cubicles, with a minimum of one (Fig. 07).<sup>[9]</sup> Example layouts for ambulant cubicles are provided in section 3.4 of this document.

A minimum of one urinal accessible to people with ambulant mobility impairments should be provided in male separate-sex facilities. In addition, a minimum of one urinal accessible to wheelchair users should be provided where separate-sex facilities are wheelchair accessible (Fig. 08).

Urinals accessible to wheelchair users and people with ambulant mobility impairments should have vertical grab

rails fitted on either side of a urinal where stall privacy dividers are not fitted, in accordance with Fig. 47 of BS8300-2:2018. It is preferable to provide vertical grab rails in addition to stall privacy dividers as shown on page 26 of this document.

Separate-sex facilities should provide washbasins with various rim heights above finished floor level as follows:

- **For people with ambulant mobility impairments, between 780 mm and 800 mm**
- **For use by children and people of short stature, between 720 mm and 750 mm**
- **Where a wheelchair accessible urinal is provided, one washbasin with its rim between 680 mm and 700 mm above finished floor level should also be provided.**<sup>[10]</sup>

Where it is impractical to provide washbasins at more than two heights, the lowest height required in that instance should be provided in addition to standard washbasins with rim 850 mm above finished floor level (Fig. 08).

Guidance on space planning for cubicles, urinals and washbasins for wheelchair users and people with ambulant mobility impairments can be found in Section 3 of this document.

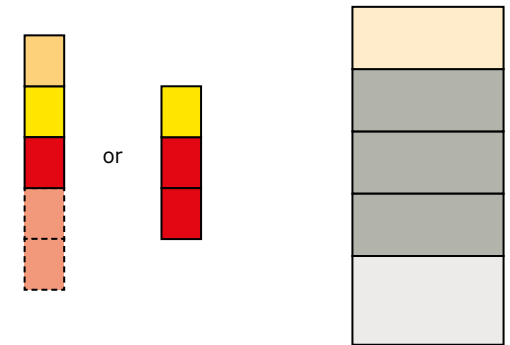

Fig. 07

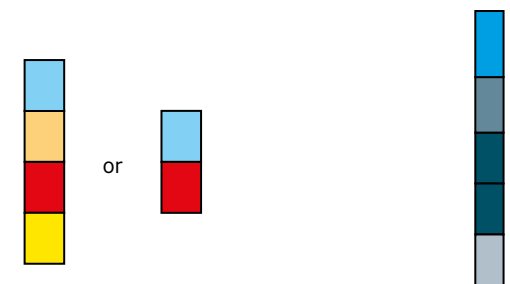
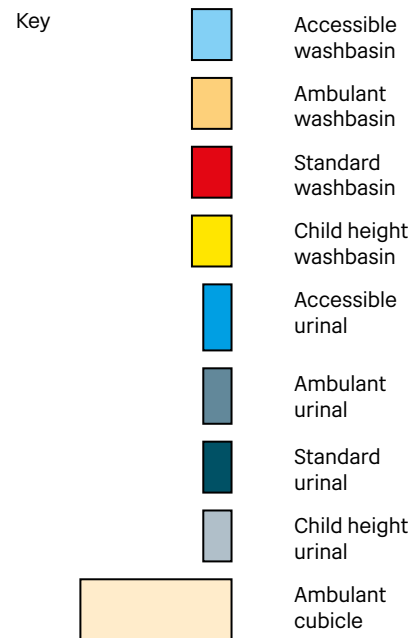
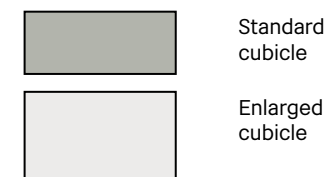

Fig. 08



9. BS6465-4:2010, 10.1.3 Men and women

10. BS8300-2:2018, 18.5.4 Accessible urinals



# Capacity and User Groups

## 2.5 Accessible and Unisex Facilities

Accessible and gender-neutral sanitary accommodation should be provided for those that require it; providing the equitable provision with the same level of dignity as separate-sex facilities.

Passenger throughput in stations may determine the quantity of unisex and accessible facilities that are to be provided. The following list describes the minimum requirements and additional recommended facilities:

### Required in all stations:

- A minimum of one unisex accessible toilet.
- A minimum of one unisex accessible baby changing facility.
- A minimum of one unisex toilet for people with ambulant mobility impairments.

### Recommended in all stations:

- A minimum of one dedicated gender-neutral self-contained toilet.

### Recommended in Category A stations:

- Changing Places toilet (see 3.14).

Where only one of any unisex/accessible facility is provided, it should be designed for right-hand transfer. Where more than one of any unisex facility can be accommodated, a choice of left-hand and right-hand transfer layouts should be provided. In large stations, it is recommended that unisex accessible toilets are provided for both left-hand and right-hand transfer to accommodate as wide a range as possible of assisted and independent disabled users.<sup>[11]</sup>

The unisex accessible toilet and unisex accessible baby changing facility have previously often been incorporated within the same room. These facilities should be provided in separate rooms to safeguard the availability of the toilet for those who need it. It is desirable, but not mandatory, for the accessible baby changing facility to incorporate a WC.<sup>[12]</sup>

Guidance on how to control access to accessible and unisex facilities is provided overleaf.

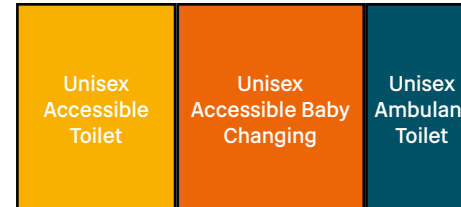

Fig. 09 - Required

Guidance on space planning for unisex facilities can be found in Section 3 of this document.

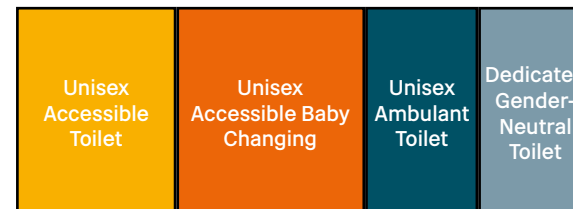
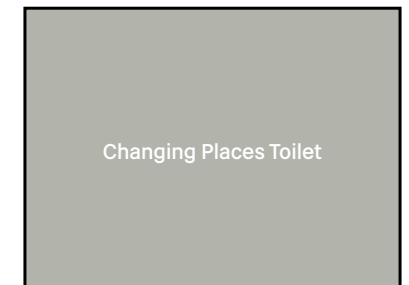

Fig. 10 - Recommended



11. BS8300-2:2018, 20.2.8 Toilet accommodation  
12. BS8300-2:2018, 18.4 Accessible baby changing facilities

# Capacity and User Groups

## 2.5 Accessible and Unisex Facilities (continued)

Accessible sanitary accommodation may be misused for other purposes such as baby feeding because no other alternatives are available. This is an unsuitable location for such an activity and may prevent access for those that require use of the accessible facilities.

All activities related to sanitary accommodation that may need to be carried out whilst in the station should be considered and provided for wherever possible. In this instance, it would be advantageous to provide a dedicated hygienic space with a washbasin for those who might need to express milk or for parents who wish to be private.

### 2.5.1 Access Control

Accessible and unisex sanitary accommodation is often subject to misuse by the general public due to the self-contained nature of these facilities. For this reason, accessible facilities should be fitted with controlled access through use of a RADAR (Royal Association for Disability and Rehabilitation) approved lock.

Unisex sanitary accommodation that is not designed for use by PRMs, such as a dedicated gender-neutral WC, should not have controlled access to safeguard the availability of the facility for all those who require it.

Specialist facilities such as a Changing Places toilet should be available and fully operational for customers who require them. Where there is a risk of a facility being mistreated by others in the station, the facility should be locked with a key or code particular to the station (not RADAR). Visitors should be able to request the code, usually through an attendant, which relies on a member of staff being available at all times.



RADAR (Royal Association for Disability and Rehabilitation) approved lock and key





Accessible/Unisex Facility Type	Access Control
 Unisex Accessible Toilet	RADAR Lock
 Unisex Accessible Baby Changing	RADAR Lock
 Unisex Ambulant Toilet	RADAR Lock
 Dedicated Gender-Neutral Toilet	No controlled access
 Changing Places Toilet	Station specific lock (accessible on request)

Table 01 - Access Control for Unisex Facilities

### 2.5.2 Inclusive Wayfinding

Inclusive wayfinding is a key part of the design of accessible and unisex facilities, facilitating easier access for persons of reduced mobility (PRMs).

Sufficient colour contrast between elements on signage should be checked using the Light Reflectance Values (LRV) of each colour. Colours should meet the industry standard of a minimum 70% LRV contrast between sign text/pictogram and background, and comply with the contrast table as in BS EN 16584-1:2017 Part 1: Contrast.

Wayfinding strategies should consider the needs of blind and partially sighted people. Toilets should be provided with repeater speakers from the public address system so that people using WC facilities do not miss important information. <sup>[13]</sup>

If braille signage is provided it should be easy to locate and should be integrated as part of a sensory or tactile trail provided to guide users to facilities.

13. BS8300-2:2018, 20.2.8 Toilet accommodation

Public Toilets In Managed Stations  
**Space Planning Guidance for Facilities**



# Space Planning Guidance for Facilities

## 3.1 Cubicle Sizes

A variety of conditions will determine the sizing of cubicles; the dimensions shown here are indicative only and are provided to assist with space planning.

In all instances capacity requirements should be considered alongside the appropriate sizing of facilities, taking into account the needs of all user groups.



Cubicle size is critical to ensuring dignity for passengers; it is unlikely that a cubicle of minimum width 800 mm will be satisfactory. Internal cubicle dimensions should be within the range shown in Figures 11 & 12. Additionally, walls between cubicles should be flush with the floor and use covered skirtings (see overleaf), necessitating a minimum partition wall depth of 75 mm.

**A circle of clearance within cubicles should not be less than 450 mm in diameter to enable the user to enter the cubicle, turn round and close the door.** No items either on the floor or attached to the wall should encroach on the circle of clearance or space above it. <sup>[14]</sup>

Toilet paper dispensers should be provided in any reasonable position outside the circle of clearance.

Where passengers are likely to be travelling with luggage, larger cubicles should be provided. Consideration should be given to stations with a high proportion of leisure travellers and/or direct airport links. Cubicles  $\geq 1000$  mm in width can accommodate a luggage zone as shown. The overlap between the luggage zone and activity space should not exceed 150 mm, and the luggage zone should not impinge on the circle of clearance. <sup>[15]</sup>

Larger standard cubicles are distinct from enlarged cubicles which have separate requirements as described in section 3.5.

-  Activity space [800 x 600]
-  Circle of clearance [ $\varnothing$  450]
-  Luggage zone [350 x 900]

Dimensions in millimetres

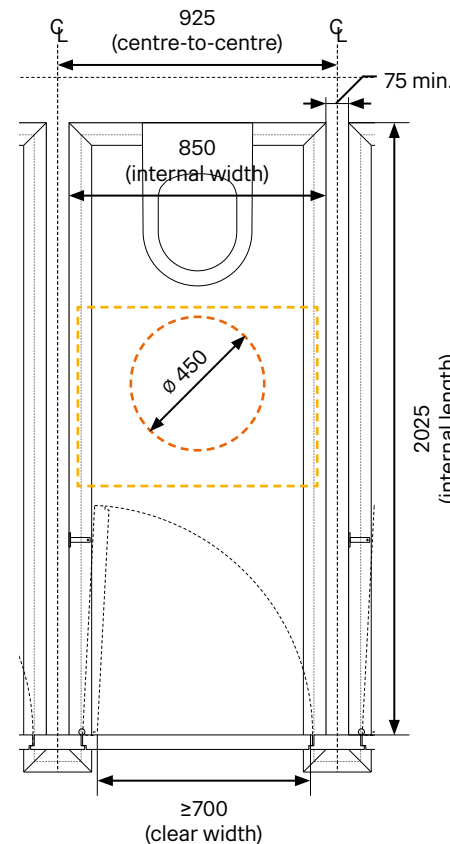

Fig. 11 - Minimum (recommended) cubicle dimensions 850 x 2025

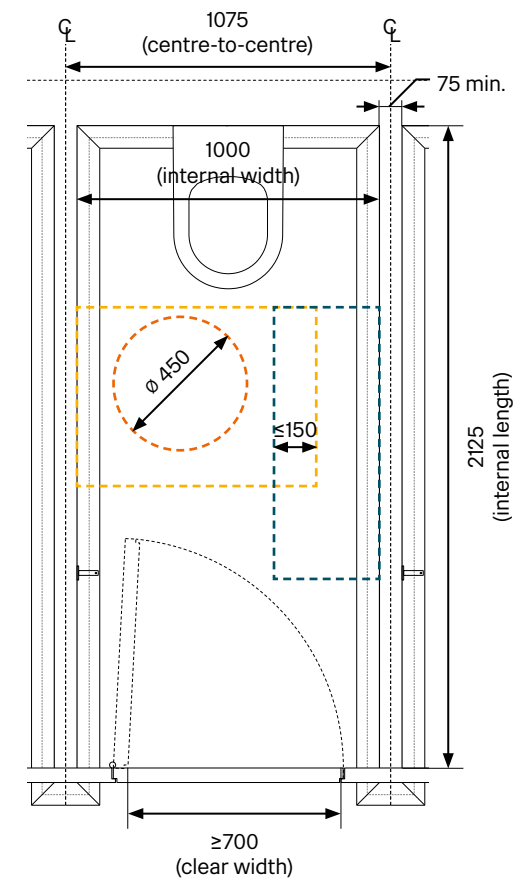

Fig. 12 - Larger (recommended) internal dimensions 1000 x 2125

14. BS6465-4:2010, 19.8.1.2 Size  
15. BS6465-4:2010, 19.8.1.5 Size

# Space Planning Guidance for Facilities

## 3.2 Cubicle Assembly

**To maximise dignity and privacy for users, walls between cubicles should be flush with the floor.** This requires a partition wall depth of at least 75 mm to accommodate coved skirting. Wall depth should be considered during initial space planning as it will impact overall capacity, particularly in longer runs. Cubicle doors should have a 125 mm floor gap to provide ventilation and assist with monitoring by staff.

Coved skirting (precast terrazzo) should form the base of cubicle wall systems, projecting 75 mm from the internal wall surface. The cove should have a radius of 40-50 mm so as not to impinge on available floor space within the cubicle. Terrazzo skirting should contrast visually with walls and floor (difference in light reflectance value between surfaces  $\geq 30$  points).<sup>[16]</sup>

The tops of cubicle doors and dividing walls should be a minimum of 2000 mm above finished floor level. To increase privacy, it is recommended to install

glass panels on top of dividing walls, continuing to finished ceiling level. Surfaces and ledges above eye level (e.g. the top surface of cubicle dividers) should be angled so that needles, knives and other potentially harmful objects cannot be stored there.

**Doors should be hung to fall open, so that vacancies are clearly visible.** Doors should be fitted with a durable locking system that is easily operable by people with limited manual dexterity, including handles where appropriate (e.g. ambulant cubicles). Locks should incorporate clearly visible colour coded signage identifying whether a cubicle is occupied or vacant.

Cubicles should contain two door hooks (which may also act as door stops), at 1400 mm and 1050 mm above finished floor level.<sup>[17]</sup>

- - - Glass Panels above 2 m
- Glass Backlit Light Panel
- Linear Ventilation Grille

Dimensions in millimetres

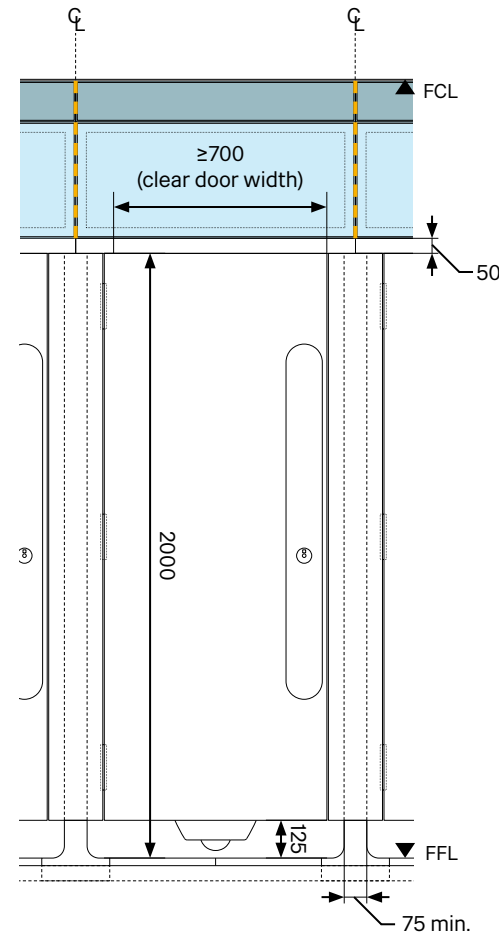

Fig. 13 - Cubicle elevation

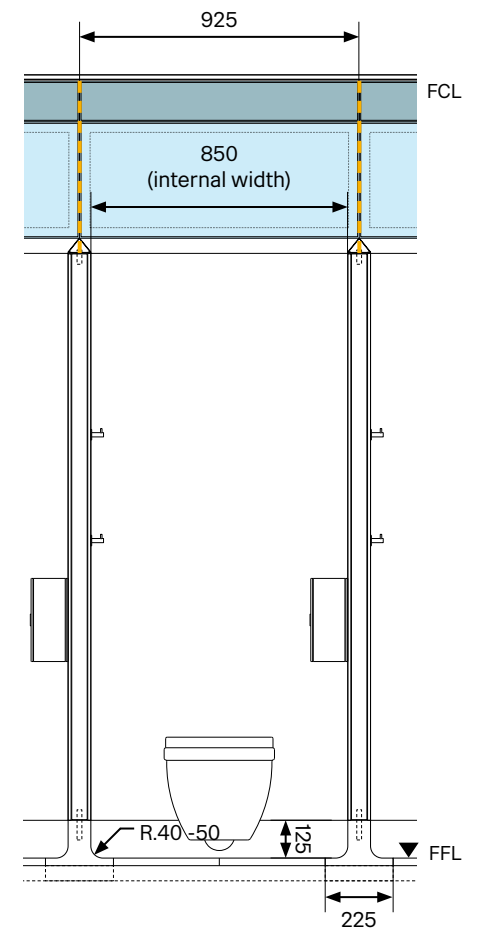

Fig. 14 - Cubicle section

16. Approved Document M Volume 2, 2015, 0.26 Definitions

17. BS8300-2:2018, 18.1.5 Clothes hooks, towel rails and shelves

# Space Planning Guidance for Facilities

## 3.2 Cubicle Assembly (continued)



Above 2000 mm, glass dividers between cubicles provide a sense of containment for users, increasing privacy and dignity.

Air extracts should be provided on the rear wall of all cubicles where practical, with linear ventilation grilles coordinated with cubicle dimensions.

It is advantageous to provide backlit light panels on the rear wall of cubicles as this brings additional illumination to the internal cubicle space, and improves visibility from circulation areas.

Continuous wall panels with service corridors to provide access from behind are preferred, (see section 4.2), however, where this is not possible, an upper access panel will be required to provide cistern access (see section 4.1).

Further guidance on cubicle materials and finishes can be found in section 6.3.

-  Glass Panels above 2 m
-  Glass Backlit Light Panel
-  Linear Ventilation Grille

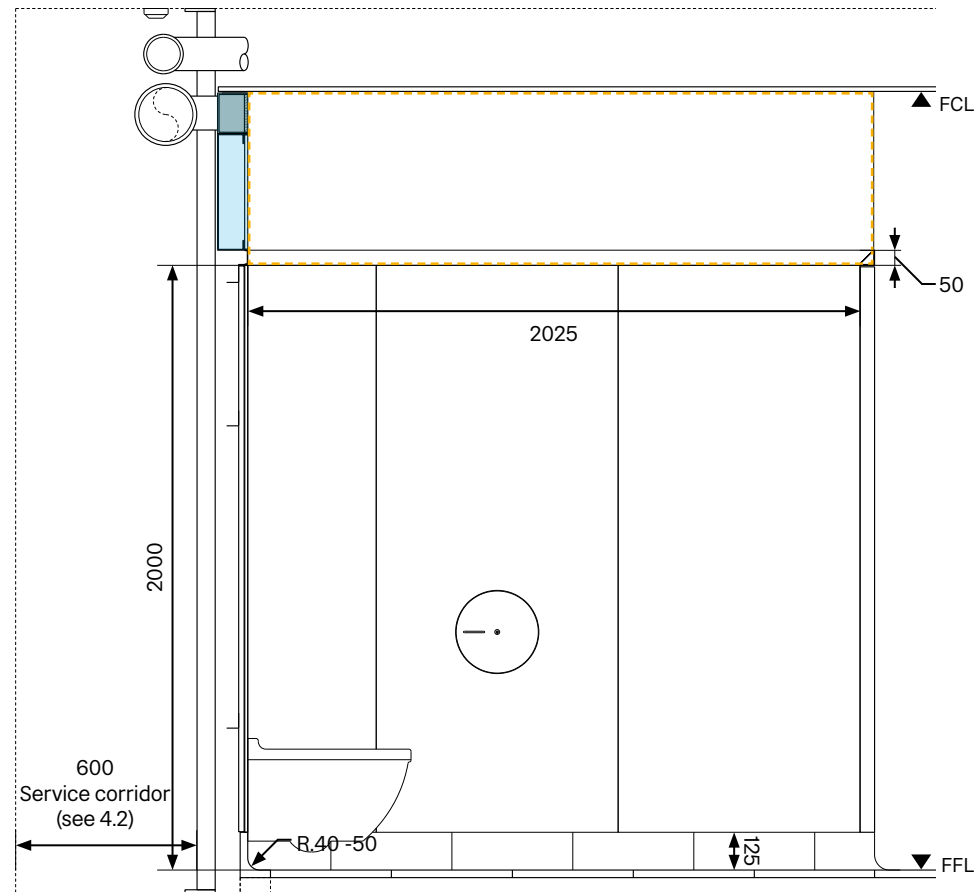
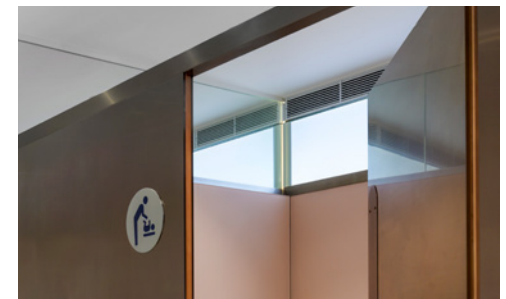

Fig. 15 - Section through cubicle

Dimensions in millimetres



Glass dividers between cubicles, London Victoria Station. Image: Peter Langdown



Rear wall of cubicle, London Victoria Station. Image: Peter Langdown

# Space Planning Guidance for Facilities

## 3.3 Female Cubicles





**Female cubicles should be designed to accommodate space for sanitary disposal bins (540mm x 210mm).**<sup>[18]</sup>

It should be noted that floor-standing sanitary disposal bins will not be able to be positioned flush to the wall where coved skirting is present.

WC pans may need to be positioned off-centre relative to the cubicle in order to accommodate sanitary disposal bins, which should not be positioned such that access, or use of, other appliances is impaired. This may mean that a wider cubicle is necessary to achieve adequate clearance between the WC pan and bin.

In addition to the space required for sanitary disposal bins, female cubicles might need to be larger than male cubicles to accommodate the user's shopping or baggage.

Toilet paper dispensers should be provided in any reasonable position outside the circle of clearance.

-  Activity space [800 x 600]
-  Circle of clearance [Ø 450]
-  Disposal bin space [210 x 540]
-  Luggage zone [350 x 900]

Dimensions in millimetres

18. BS6465-2:2017, Table 1 - Nominal appliance spaces

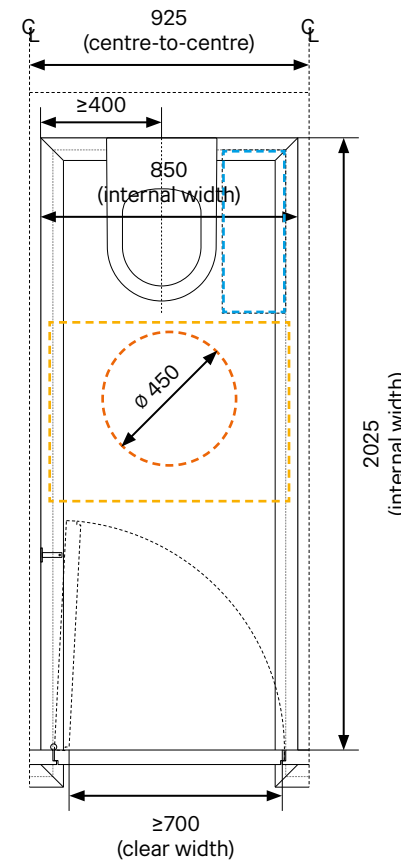

Fig. 16 - Minimum (recommended) internal dimensions 850 x 2025

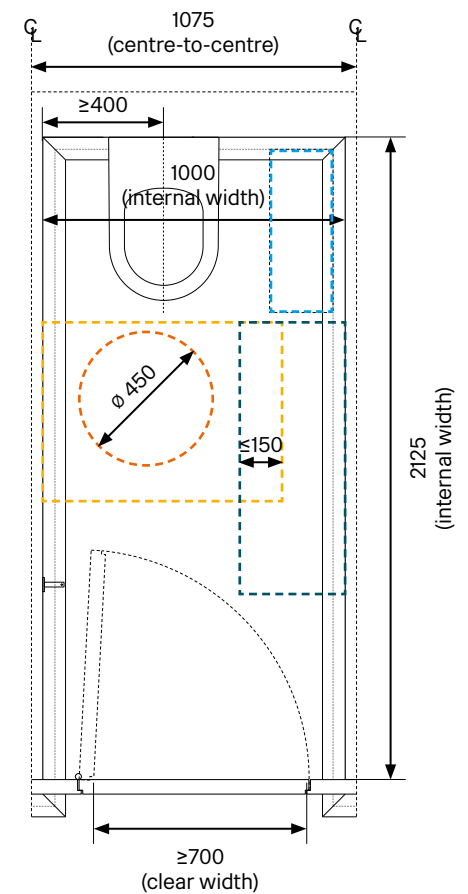

Fig. 17 - Larger (recommended) internal dimensions 1000 x 2125

# Space Planning Guidance for Facilities

## 3.4 Ambulant Cubicles

**Accessible WC compartments for people with ambulant mobility impairments, often referred to as 'ambulant cubicles', should make up 10% of cubicles (with a minimum of one).** Where more than one ambulant cubicle is provided, left and right handed doors are to be provided. <sup>[19]</sup>



Ambulant cubicles should be a minimum of 800 mm in width, and have a minimum clearance of 750mm between the WC pan and internal door face (activity space). Doors will be outward opening with a minimum clear width of 700 mm. <sup>[20]</sup>

Ambulant cubicles 800 mm - 1000 mm in width should be designed in accordance with Fig. 46 of BS8300-2:2018. For cubicles >1000 mm the arrangement of grab rails and WC pan should be designed in accordance with Fig. 39 of BS8300-2:2018.

The placement of ambulant cubicles should be considered as the outward opening door may affect circulation. For this reason, ambulant cubicles are often located at the end of a run of cubicles, however, proximity to the WC entrance/exit should consider any persons of reduced mobility.

Where WC cisterns cannot be used as a shelf, a separate shelf surface should be provided, 950 mm above finished floor level, for colostomy bag changing. <sup>[1]</sup> The provision of a shelf will need to be considered against security requirements on an individual station basis.

Toilet paper dispensers should be provided in any reasonable position that does not impinge on grab rails.

-  Activity space [800 x 750]
-  Disposal bin space [210 x 540]
- A** Shelf [285 x 185]

Dimensions in millimetres

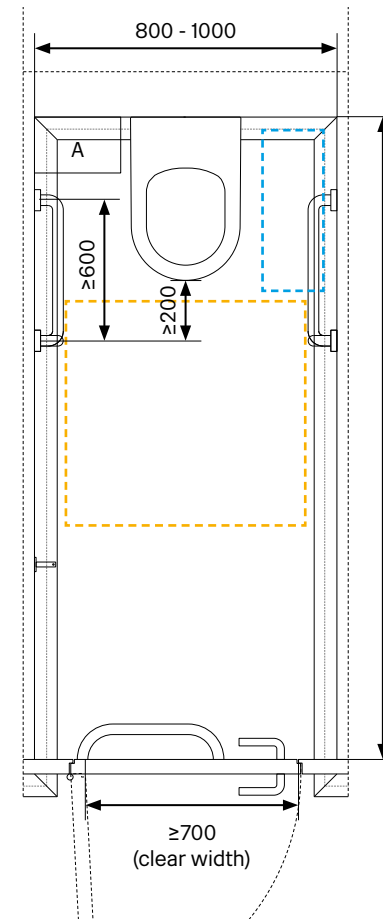

Fig. 18 - Ambulant cubicle with width 800 - 1000 mm

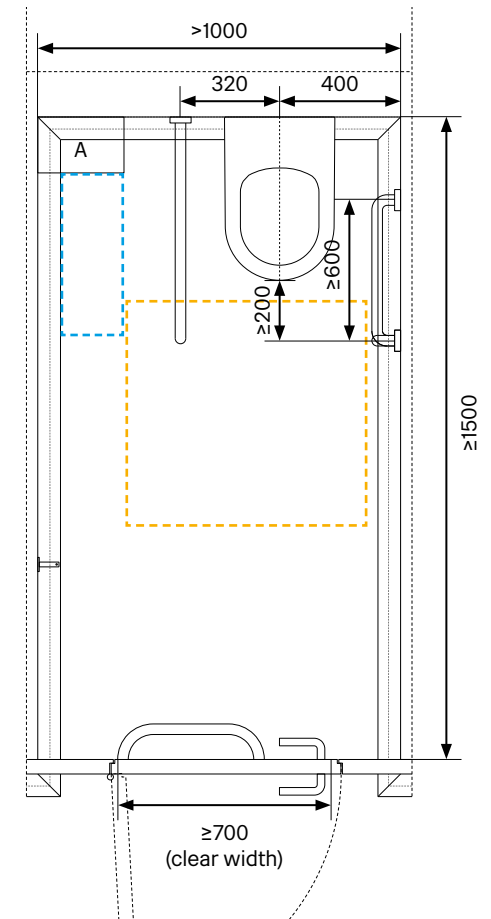

Fig. 19 - Ambulant cubicle with width >1000 mm

19. Guidance for the Provision of WC facilities for Network Rail, 8.16 / 8.18

20. BS8300-2:2018, 18.5.3.3 WC compartments or cubicles accessible by people with ambulant mobility impairments



# Space Planning Guidance for Facilities

## 3.5 Enlarged Cubicles

**Enlarged cubicles of minimum width 1200 mm should be provided where four or more WC cubicles are provided in a separate-sex area.**<sup>[21]</sup> Enlarged cubicles should be provided in addition to any requirements for cubicles for people with ambulant mobility impairments.





Enlarged cubicles are particularly beneficial in stations as they are designed to accommodate passengers who require more space, including, but not limited to, pregnant women, older people, people with luggage or shopping, and people with children.

Enlarged cubicles can also incorporate a baby-changing unit, although family toilets (see section 3.6) are the preferred option when providing baby-changing.

Where enlarged cubicles do contain a baby-changing unit, they should be positioned at the end of a run of cubicles to allow a pushchair to be parked outside of the cubicle. It is preferable for such cubicles to be fitted

with outward opening doors. Circulation space leading to enlarged cubicles containing baby-changing units should be a minimum of 1500 mm deep to allow for people and pushchairs to pass.

Within enlarged cubicles with baby-changing units it is preferable to provide a washbasin and/or wall mounted toddler seat with restraints where space permits. Baby-changing units should be mounted 750mm above finished floor level. Requirements for a nappy disposal bin should be considered against station security risks.

-  Activity space [800 x 600]
-  Circle of clearance [ $\varnothing$  450]
-  Disposal bin space [540 x 210]
-  Luggage zone [350 x 900]
- A Baby-changing unit [440 x 845]
- B Toddler seat [350 x 305]

Dimensions in millimetres

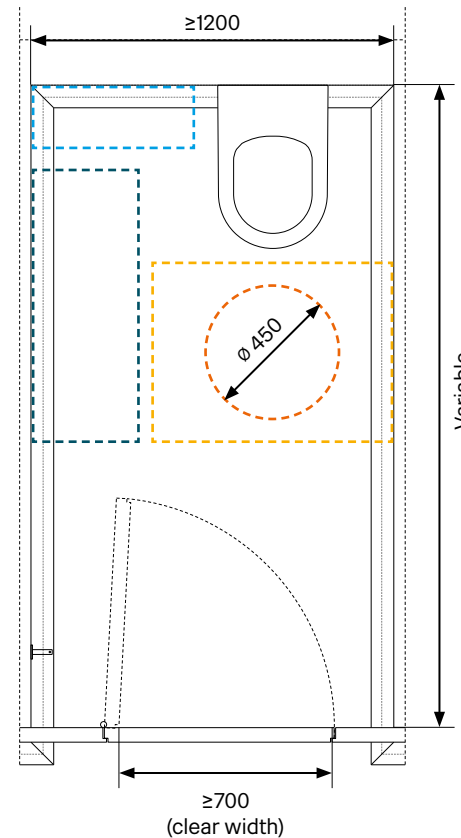

Fig. 20 - Enlarged cubicle

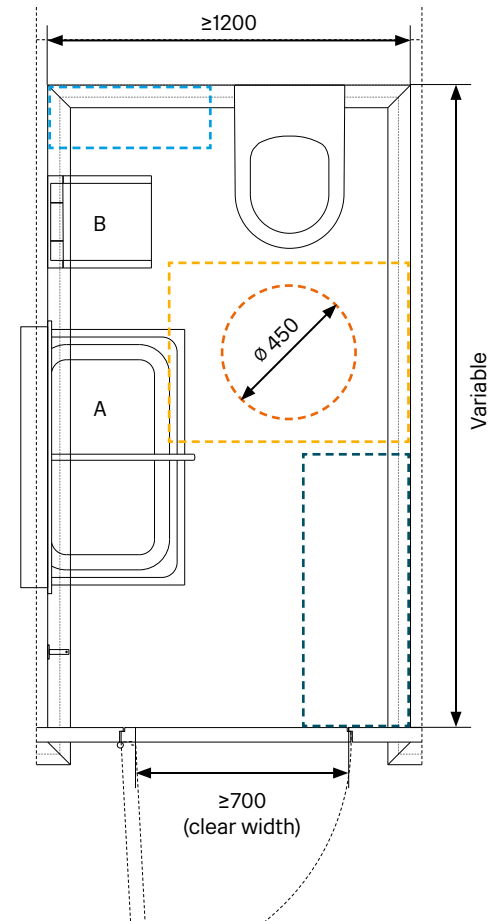

Fig. 21 - Enlarged cubicle with baby-changing unit

21. BS6465-4:2010, 10.3.2 d) - Disabled people

# Space Planning Guidance for Facilities

## 3.6 Family Toilets

Family Toilets are the preferred option to provide baby-changing within separate-sex facilities, however, the space requirement for a family toilet should be considered against capacity requirements. Where space is severely constrained, enlarged cubicles with baby-changing units should be used.





Where separate-sex facilities are provided, baby-changing in male and female areas should be provided, with greater provision of baby-changing in female areas.

**Family toilets contain a WC, washbasin and baby-changing unit, and should be large enough to accommodate a double buggy.** It is preferable to provide both a wall mounted toddler seat with restraints and an additional, smaller, WC pan for children where space permits.

Cubicles with baby-changing and sufficient internal space to accommodate a double buggy should have doors with a minimum clear width of 850 mm.<sup>[22]</sup>

The layout shown can be converted to a family toilet accessible to people with ambulant mobility impairments through the addition of grab rails, and an outward opening door without increasing the internal cubicle dimensions.

Nominal dimensions for baby-changing units can be found in Table 1, Section 5.1 of BS6465-2:2017. An alternative layout for a family toilet with a screened WC is shown in Figure 27 of BS 6465-2:2017.

-  Activity space [800 x 600]
-  Circle of clearance [ø 450]
-  Disposal bin space [540 x 210]
-  Double buggy space [1500 x 760]
- A Baby-changing unit [440 x 845]
- B Toddler seat [350 x 305]
- C Child WC [Varies]

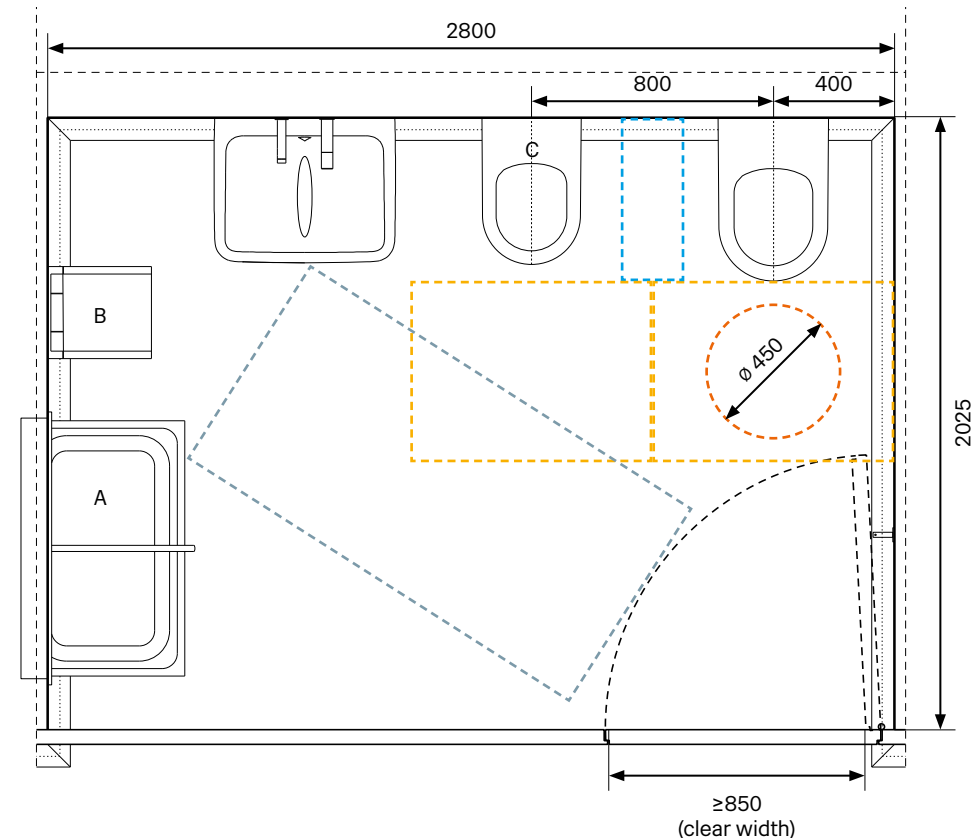

# Space Planning Guidance for Facilities

## 3.7 Urinals

**Urinals are to be 'bowl' type urinals and should not be waterless.** Urinals should be spaced at 700 mm centres minimum. It is recommended to install privacy screens between urinals; where privacy screens are used, urinals should be spaced at 800 mm centres minimum.<sup>[23]</sup> Reflective surfaces should not be used in urinal areas where these could compromise privacy.



**The rim height of a standard urinal should be 620 mm above finished floor level, 500 mm for urinals accessible to people with ambulant mobility impairments and 380 mm for a wheelchair accessible urinal.**<sup>[24]</sup>

A minimum of one urinal should be provided with rim height 380mm for use by children and people of short stature. A minimum of one urinal accessible to people with ambulant mobility impairments should be provided, and a minimum of one urinal accessible to wheelchair users (with an enlarged activity space of 900 mm x 1400 mm)

should be provided where facilities are wheelchair accessible.

Where ambulant and wheelchair accessible urinals are provided the urinal rim should project at least 360 mm from the wall face.<sup>[2]</sup> These urinals should have vertical grab rails where privacy dividers are not fitted in accordance with Fig. 47 of BS8300-2:2018. It is preferable to provide vertical grab rails in addition to stall privacy dividers to provide an equitable level of privacy and dignity to all users.

Continuous wall panels with service corridors to provide access from behind are preferred, (see section 4.2), however, where this is not possible, an upper access panel will be required to provide cistern access (see section 4.1).

-  Activity space [800 x 500]
-  Ambulant activity space [800 x 500]
-  Wheelchair activity space [900 x 1400]

Dimensions in millimetres

23. BS6465-4:2010, 19.9.1 - Urinals  
24. BS8300-2:2018, 18.5.4 - Urinals accessible to wheelchair users and people with ambulant mobility impairments

Fig. 23 - Urinal Plans

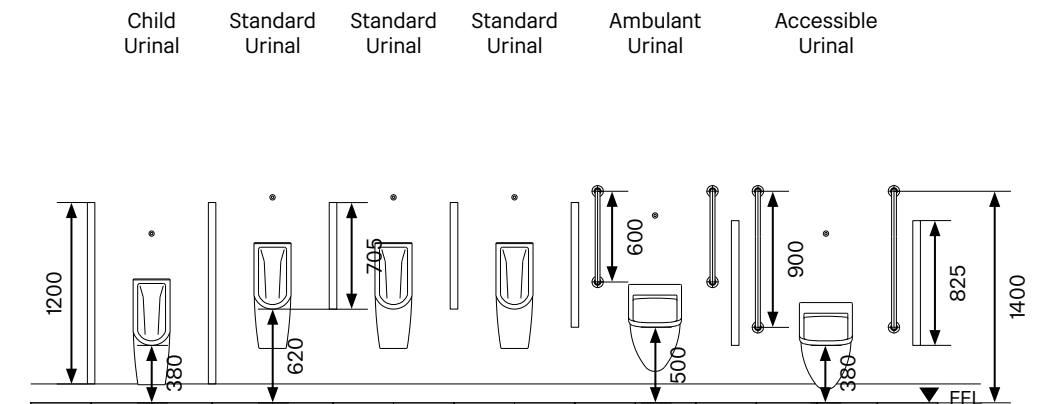
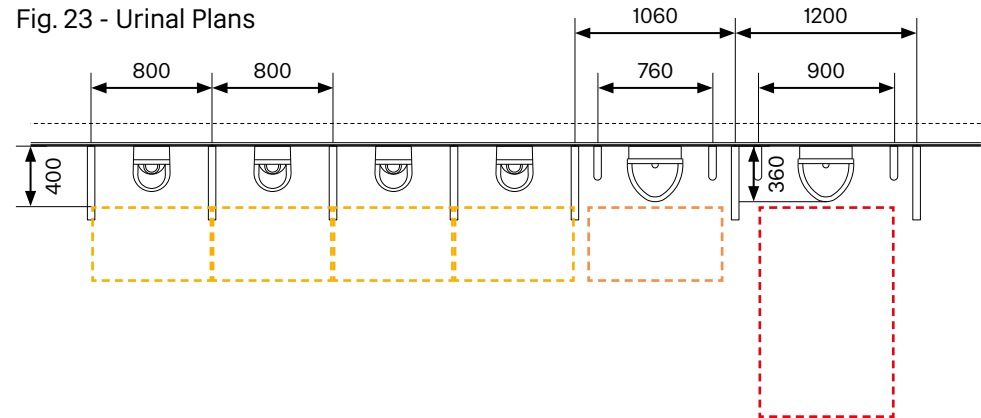

Fig. 24 - Urinal Elevations

# Space Planning Guidance for Facilities

## 3.8 Wash Troughs

Wash troughs should be used in stations as they offer a clear single point of amenity, reducing spills and providing greater flexibility to the customer. **Wash troughs with integrated taps and soap dispensers should be positioned at 700 mm centres (minimum).**<sup>[25]</sup> Hand-washing and drying appliances should be sensor operated in separate-sex WC's.<sup>[26]</sup> Hand dryers should be positioned above wash troughs at 700mm centres (minimum), recessed within a vanity unit, and positioned so that water drains into the troughs, minimising spillage on floor surfaces.

**The rim of a standard wash trough should be 850 mm above finished floor level.** Alternative heights for wash troughs are detailed overleaf. Product dimensions shown here are indicative only and are provided to assist with space planning.

Consideration should be given to the use of foam soap, which dispenses a reduced amount of product compared to liquid soap. This requires power and a pump within the tap or trough assembly.

Where space permits, a separate vanity area with shelves and mirrors should be provided in female WC's so that access to the wash troughs is not restricted by people doing their hair and make-up. Such an area may encourage inappropriate drug use, and should therefore be located in a highly visible area covered by CCTV.



Wash troughs, London Victoria Station. Image: Peter Langdown

- Hand dryer
- Tap
- Soap Dispenser

Dimensions in millimetres

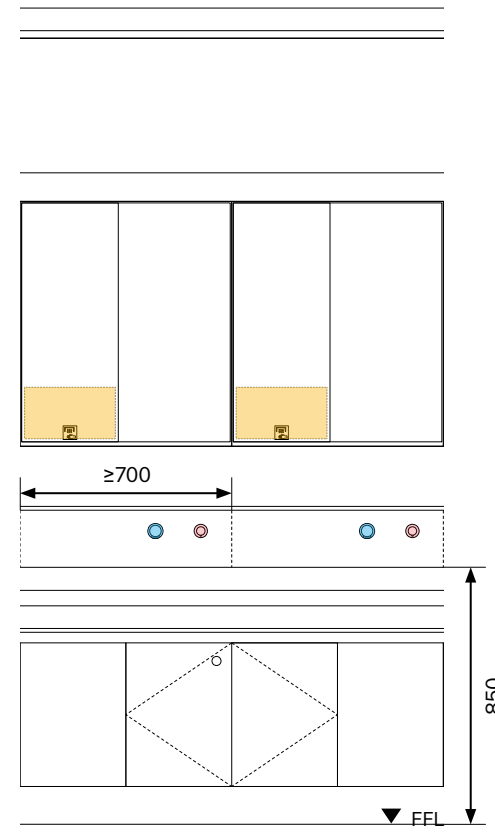

Fig. 25 - Wash Trough Elevation

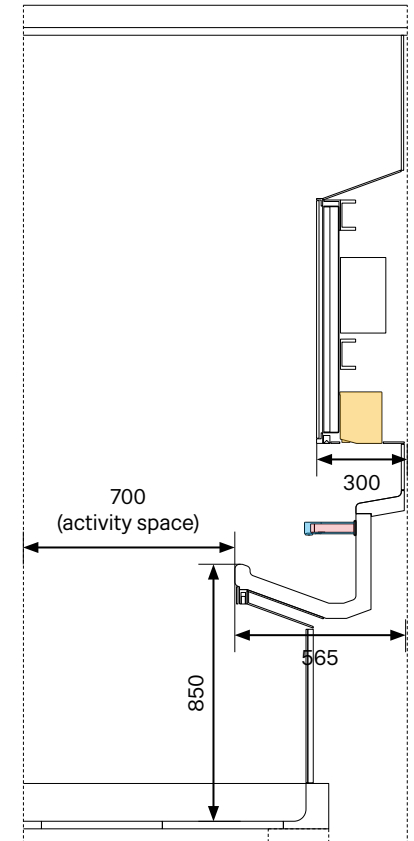

Fig. 26 - Wash Trough Section

25. BS 6465-2:2017, Figure 8 - Range of washbasins

26. BS6465-4:2010, 19.10.1.6 Hand washing

# Space Planning Guidance for Facilities

## 3.8 Wash Troughs (continued)

To make that wash troughs are available and accessible to all users, they may need to be provided at multiple heights. The following dimensions refer to the rim height above finished floor level:

- **680 mm - 700 mm for wheelchair users, where a wheelchair accessible urinal is provided** <sup>[27]</sup>
- **720 mm - 750 mm for use by children and people of short stature** <sup>[28]</sup>
- **780 mm - 800 mm for people with ambulant mobility impairments** <sup>[29]</sup>

Where it is not practical to provide wash troughs at more than two heights, the lowest height required in that instance should be provided in addition to standard wash troughs with rim 850 mm above finished floor level.

Vanity units and, as a result, hand dryers should be lowered accordingly to make sure they are a consistent height above the wash trough rim. The interface between wash troughs and vanity units of different heights should be considered by designers; additional space may be required for a 'transition zone' or additional framing.

Where practical, wash troughs of different heights should be in separate runs or separated by a wall.

Wash troughs for wheelchair users and for people with ambulant mobility impairments should have an unobstructed activity space 800 mm wide x 1100 mm deep. <sup>[29]</sup>

The activity spaces shown are specific to the wash-troughs they are shown with. Standard activity spaces are described on the following page.

Further guidance on the materials and finishes of wash troughs and associated fittings in section 6.4.

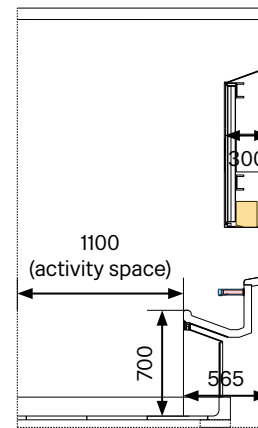

Fig. 27 - Accessible Wash Trough Section

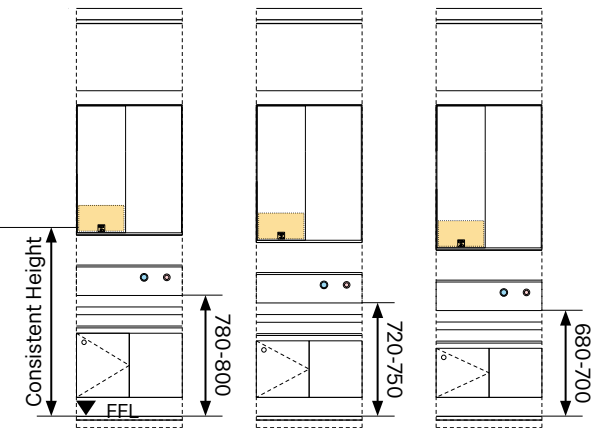

Fig. 28 - Non-standard wash trough elevations

- Activity space
- Hand dryer
- Tap
- Soap Dispenser

Dimensions in millimetres

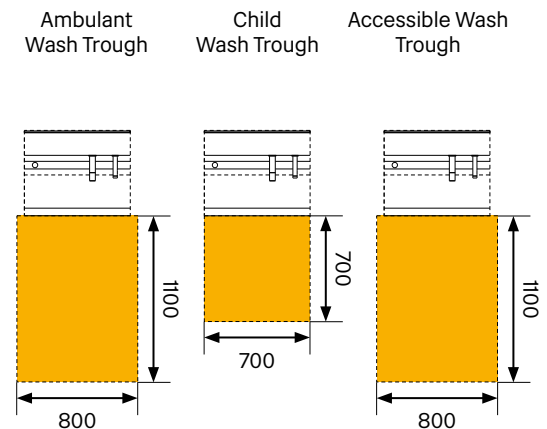

Fig. 29 - Non-standard wash trough plans

27. BS8300-2:2018, 18.5.4 Urinals accessible to wheelchair users and people with ambulant mobility impairments

28. BS6465-4:2010, 19.10.1.3 Hand washing

29. BS8300-2:2018, 18.5.5.2 Washbasins accessible to people with ambulant mobility impairments

# Space Planning Guidance for Facilities

## 3.9 Activity Spaces

An activity space of 700 mm should be provided in front of each wash trough, 600 mm in front of each cubicle and 500 mm in front of each urinal. These should not impinge on the general circulation space, and the activity spaces should not overlap. <sup>[30]</sup>

These activity spaces are for standard appliances only. Appliances for wheelchair users or people with ambulant mobility impairments may have varying requirements.

Note: Urinals are shown with a nominal depth of 400 mm in accordance with Table 1 of BS6465-2:2017, certain products will be shallower than this.

Layouts should be designed so that toilets, washbasins, and hand drying facilities are provided in a logical sequence. The relative position of appliances should also consider the placement of circulation space and the entrance(s) and exit(s).

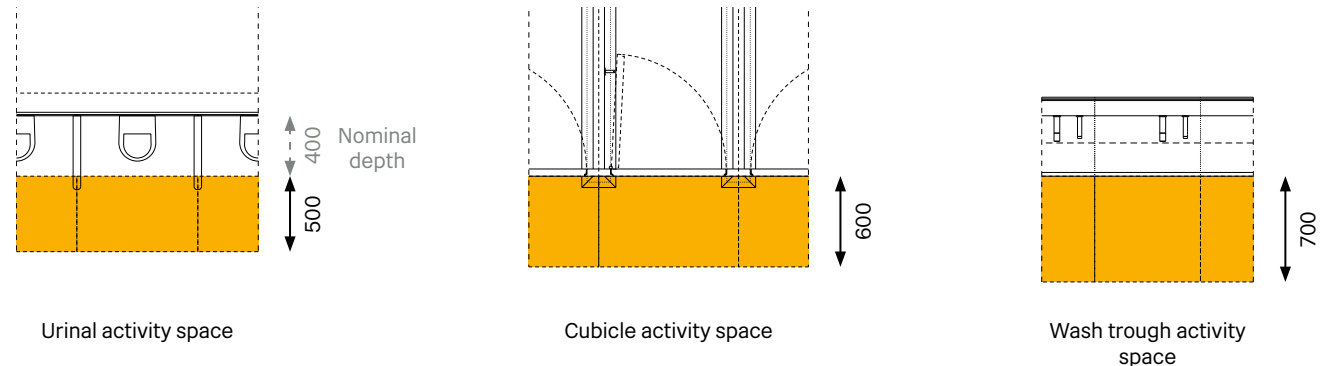

Fig. 30 - Standard activity spaces

 Activity space

Dimensions in millimetres

30. BS6465-4:2010, 19.3.4 - Circulation space

# Space Planning Guidance for Facilities

## 3.10 Circulation Spaces

**An additional circulation space of 600 mm minimum should be provided in addition to the activity spaces described on the previous page.**

If appliances face each other, only one circulation space between the two activity spaces is required. The circulation space of 600 mm is suitable for runs of up to 6 appliances, and should be increased to 900 mm or greater for longer runs. <sup>[31]</sup>

Where a short run of cubicles (up to 4) face washbasins, it is permitted to omit the 600 mm activity space where layouts are particularly constrained, however, this is not recommended. <sup>[31]</sup>

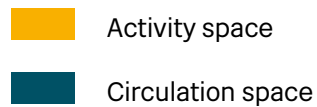

Dimensions in millimetres

Activity space and circulation space for runs of appliances  $\leq 4$

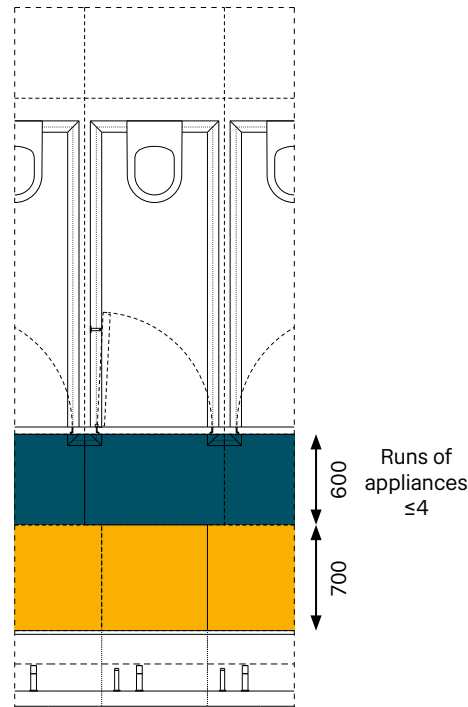

Activity spaces and circulation space for runs of appliances  $\leq 6$

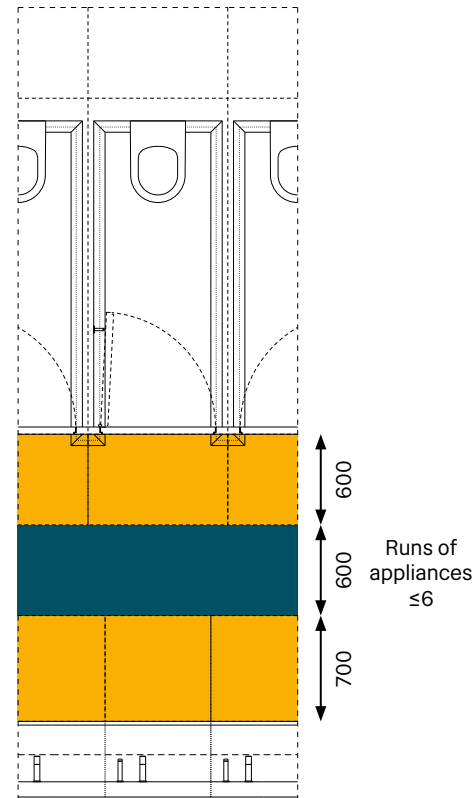

Activity spaces and circulation space for runs of appliances  $> 6$

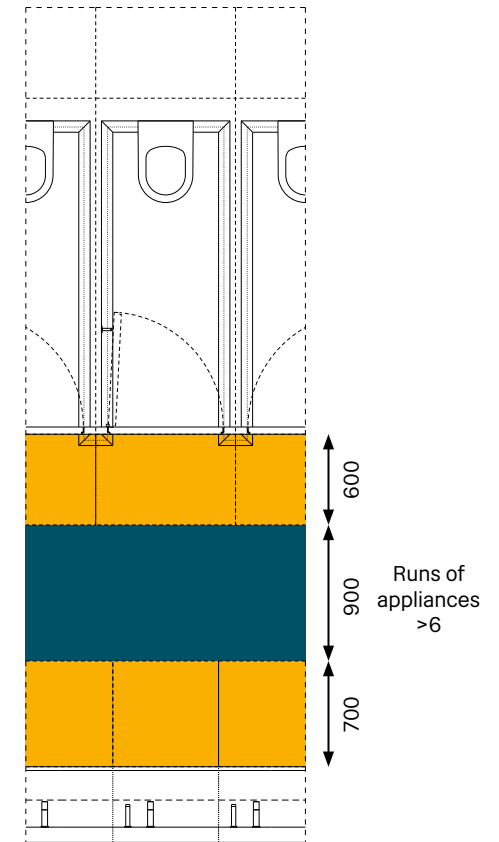

Fig. 31 - Standard circulation and activity spaces

31. BS6465-4:2010, 19.3.5 - Circulation space

# Space Planning Guidance for Facilities

## 3.11 Entrance Spaces

**It is preferable for separate-sex and unisex facilities to have a single entrance, providing a clear gateway to avoid unnecessary confusion.**

Entrances should be considered in the context of overall capacity, as separate-sex entrances may increase capacity in certain circumstances.

**Access routes to accessible facilities should be step-free. Where unisex/accessible facilities are not located within the main toilet block, clear signage should be provided at the entrance indicating the location of the closest accessible facilities.**

Unisex accessible toilets should be located as close as possible to the entrance and/or waiting area of a station. Unisex accessible baby changing facilities, gender-neutral toilets and Changing Places should be located in close proximity to the unisex accessible toilet.

The primary entrance to WC's within managed stations should be a minimum

of 1800 mm clear width to allow two wheelchair users to pass each other,<sup>[32]</sup> however, **it is recommended to provide an entrance of at least 2400 mm clear width to make certain people entering and leaving can do so without congestion.** Where toilet facilities are not wheelchair accessible, the primary entrance should have a minimum clear width of 1600 mm.<sup>[33]</sup>

The unobstructed width of any escape route to any WC (separate-sex and unisex/accessible) should be a minimum of 1200 mm.<sup>[34]</sup> Where the width of an entrance/exit corridor is below 1800 mm and the corridor length is significant, passing places of minimum width 1800 mm should be provided at reasonable intervals for wheelchair users.<sup>[35]</sup>

Collapsible gates or overhead shutters should be used to secure sanitary accommodation. These should be able to be locked open without impinging on clear widths and heights.

Where toilets within managed stations are accessed from within the station premises, entrance mats should not be used. Where different flooring materials abut each other, e.g. concourse and WC's, they should have similar levels of slip resistance.<sup>[36]</sup>

It is recommended to provide seating and areas for people to wait within shared WC entrances. Consideration should be given to how those waiting may obstruct flows into WC's and/or flows on the concourse.

Consideration should be given to the method by which toilet entrances are monitored. Monitoring by staff in addition to clearly visible CCTV can be an effective deterrent to antisocial behaviour (see section 4.1). Toilet facilities in managed stations should have an attendant present whenever the facilities are open for public use. The primary role of any attendant is to assist those who require access to unisex/accessible facilities, however, attendants may also be employed to monitor toilet entrances.

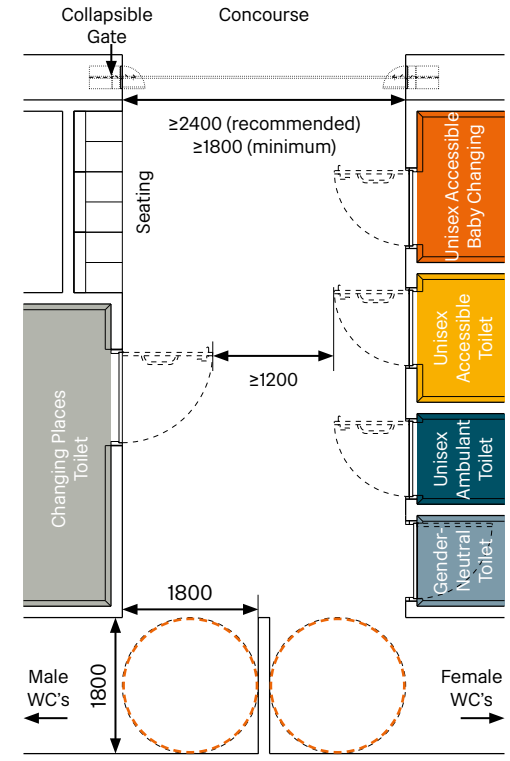

Fig. 32 - Example of a primary entrance to WC's, with direct access to all unisex/accessible facilities and secondary entrances to separate-sex facilities. Full extents of unisex/accessible facilities not shown.

32. BS8300-2:2018, 9.1 Horizontal movement  
33. BS6465-4:2010, 19.2 Entrances to the toilet block

34. BS9999:2008, 176.2 Corridors and escape routes  
35. BS8300-2:2018, 9.1.2 Dimensions of corridors

36. BS8300-2:2018, 11.3 Floor Surfaces

Turning space (wheelchair users) [ø1800]



# Space Planning Guidance for Facilities

## 3.12 Accessible Toilet and Baby Changing

**Unisex accessible toilets should be provided wherever toilets are provided within a station.** These should have internal dimensions of 2200 mm x 1700 mm, with an outward opening door of minimum clear width 900 mm, designed in accordance with Fig. 40 of BS8300-2:2018.

**A unisex accessible baby changing facility should be provided in a separate room to the unisex accessible toilet, in order to safeguard the availability of the toilet for users who need it.**

It is desirable for an accessible baby changing facility to incorporate a WC.<sup>[37]</sup>

Accessible baby changing facilities should have internal dimensions of 2200 mm x 2000 mm, with an outward opening door of minimum clear width 900 mm, designed in accordance with Fig. 29 of BS 6465-2:2017.

 Wheelchair turning space [Ø 1500]

Dimensions in millimetres

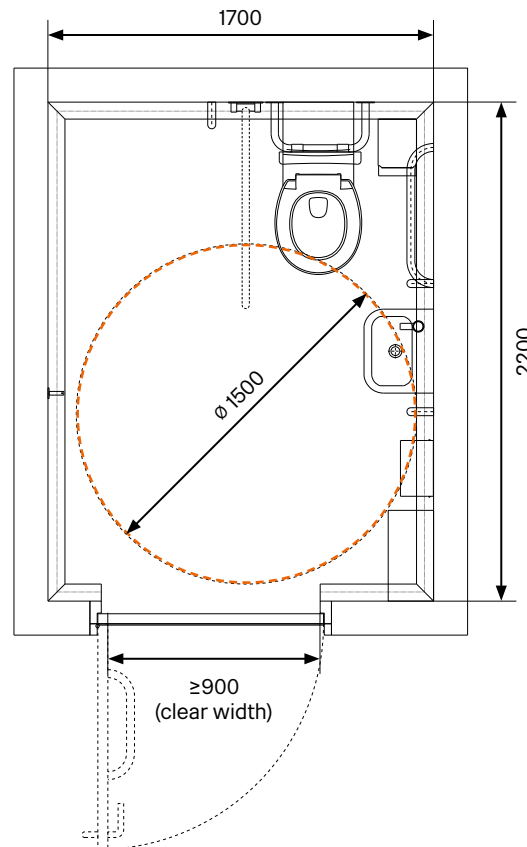

Fig. 33 - Unisex accessible toilet

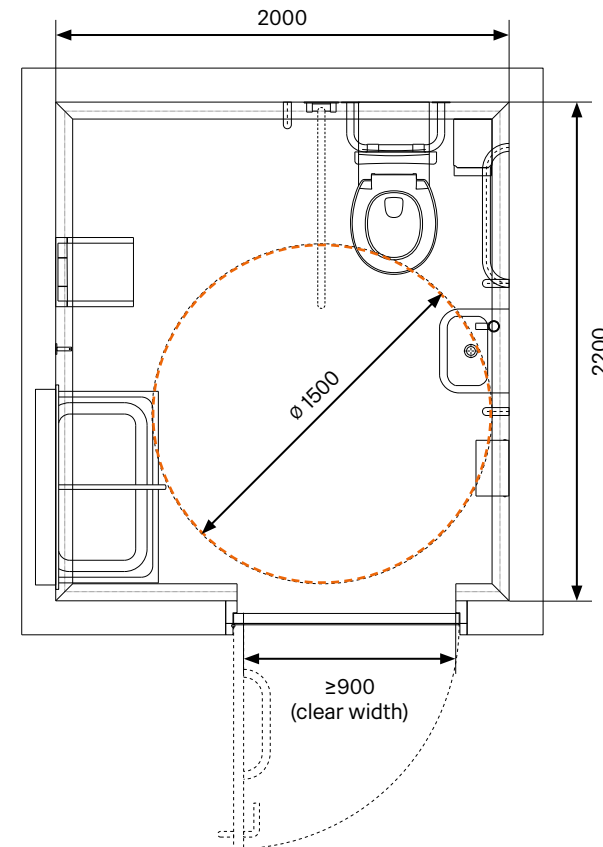

Fig. 34 - Unisex accessible baby changing facility

37. BS8300-2:2018, 18.4 Accessible baby changing facilities

## 3.13 Gender-Neutral Toilet/ Ambulant Accessible

Network Rail recognises that historically gender based toilet provision is not equitable. 50:50 male / female provision does not take account of females typically requiring more time to use sanitary facilities and increasingly people identify themselves as non-binary and may want to use gender neutral toilet facilities.

Individual WC stalls that are lockable and offer visual and acoustic privacy have similar characteristics to ambulant accessible facilities.

**Where space permits, it is advantageous to provide a dedicated self-contained gender-neutral toilet in addition to an unisex ambulant accessible toilet for an inclusive and equitable environment.**

Where separate-sex cubicles are provided, at least one unisex self-contained toilet for use by people with ambulant mobility impairments should be provided in accordance with Fig. 39 of BS8300-2:2018. [38]

Where one unisex self-contained toilet is provided, it has the primary function of providing a toilet for use by people with ambulant mobility impairments, and the secondary function of providing a gender-neutral facility.

Unisex self-contained toilets, whether ambulant accessible, gender-neutral, or both, should be located with other unisex facilities outside of separate-sex areas.

Where WC cisterns cannot be used as a shelf, a separate shelf surface should be provided, 950 mm above finished floor level, for colostomy bag changing.

[39] The provision of a shelf should be considered against security requirements for individual stations.

Toilet paper dispensers should be provided (separate to paper towel dispensers). These should be provided in a reasonable position on the wall surface closest to the WC pan, not impinging on grab rails.

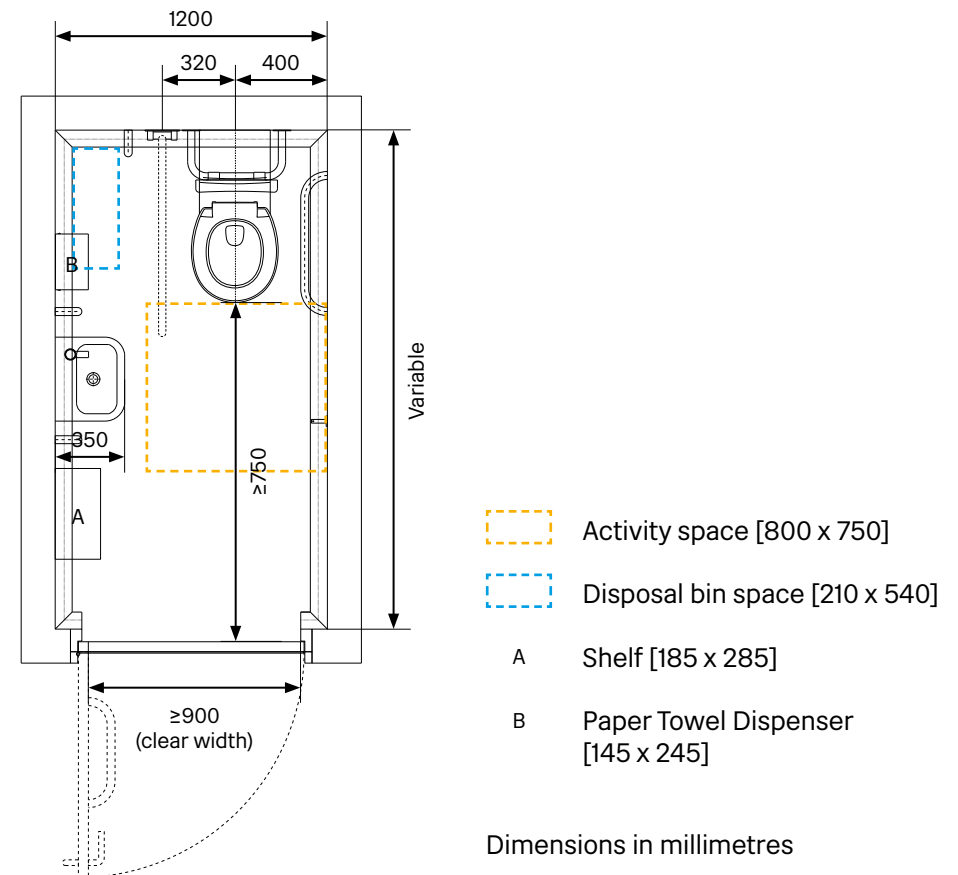

Fig. 35 - Unisex ambulant accessible toilet (Gender-neutral)

38. BS8300-2:2018, 18.5.1 Provision and location of toilet accommodation

39. BS8300-2:2018, 18.5.3.3 WC compartments or cubicles accessible by people with ambulant mobility impairments

# Space Planning Guidance for Facilities

## 3.14 Changing Places

**Changing Places toilets are for use by people with complex and multiple impairments who require the help of up to two assistants. These specialist facilities should be provided in addition to the provision of standard and accessible toilets.**

Changing Places toilets should be provided in building complexes such as major transport termini or interchanges, e.g. large railway stations and airports.

<sup>[40]</sup> **Managed Stations that are Category A should provide Changing Places toilets.**

Changing Places toilets should have internal dimensions of 3000 mm x 4000 mm, with an outward opening door of minimum clear width 1000 mm, designed in accordance with Fig. 48 of BS8300-2:2018.

Further advice on the design and installation of Changing Places toilets,

including dimensioned layouts, is available through the Changing Places Consortium.<sup>[41]</sup> The inclusion of a shower is optional, and should be assessed on an individual station basis based on the likelihood of misuse. To mitigate misuse Changing Places toilets should have station-specific controlled access (see section 2.5).

For further guidance on Changing Places toilet signage, see section 5.7.

In certain circumstances, toilets may continue to be identified as undersized Changing Places toilets if the minimum room dimensions are less than 12sqm, where this is the only option within an existing building.

It is preferable to provide an undersized Changing Places toilet than to not provide one, however, those intending to design an undersized Changing Places toilet should seek advice from the Changing Places Consortium during the initial design stage. It is highly recommended that Changing Places toilets meet the British Standard of 12sqm in order to gain certification with the Changing Places Consortium.

40. BS8300-2:2018, 18.6 Changing Places toilets  
41. For England, Wales and Northern Ireland: telephone 020 7696 6019, email [ChangingPlaces@mencap.org.uk](mailto:ChangingPlaces@mencap.org.uk). For Scotland: telephone 01382 385 154, email [PamisChangingPlaces@dundee.ac.uk](mailto:PamisChangingPlaces@dundee.ac.uk). <http://www.changing-places.org/>

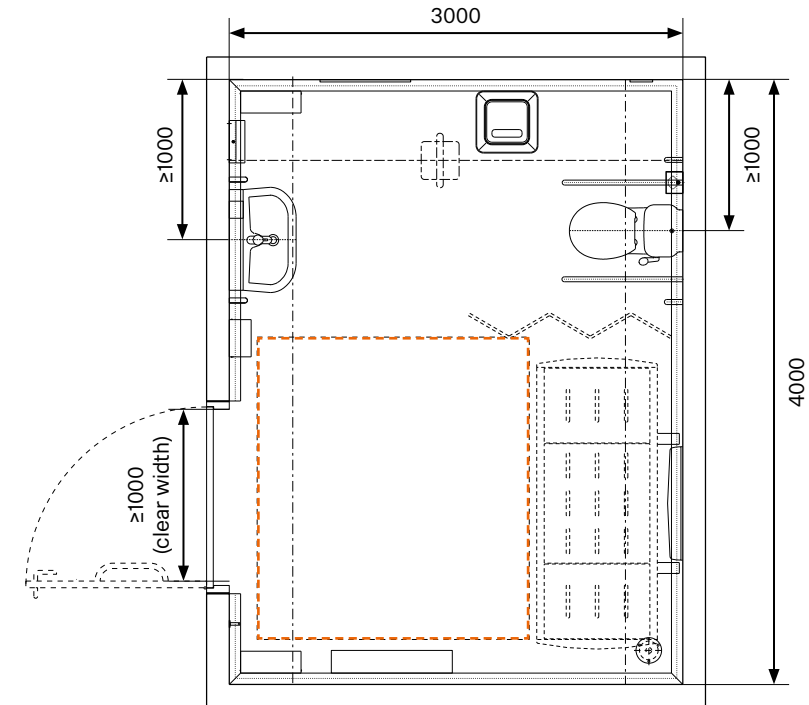

Fig. 36 - Changing Places Toilet

 Clear manoeuvring space [2000 x 1800]

Dimensions in millimetres

# Space Planning Guidance for Facilities

## 3.15 Assistance Dog Spending Areas

Assistance dog toilets or spending areas are a useful additional facility that allows people who use assistance dogs to toilet their dogs in a safe and clean manner.<sup>[42]</sup> These should be provided, space permitting, where there is no local access to suitable external spaces.

These facilities can be located in internal or external environments, as long as they are easily located, safe and secure. Internal environments should use appropriate materials to assist cleaning, be well ventilated and illuminated. Floor surfaces should be 50% hard standing or tiled equivalent, and 50% grass, with a 1:40 gradient to assist with drainage.

Assistance dog spending areas should be accessible to wheelchair users, with recommended internal dimensions of 3000 mm x 4000 mm, and an outward opening door of minimum clear width 1000 mm. These dimensions are

indicative only and are provided to assist with space planning. Cleaning regimes for station WC's are to take into account dog toilets and spending areas which should be cleaned frequently enough to make certain they are not becoming heavily soiled.

Further guidance on where to provide these facilities and how to design them can be found in the Guide Dogs for the Blind Association publication 'Guidance on the provision of spending facilities for guide dogs and other assistance dogs'.<sup>[43]</sup>



Entrance to dog spending area, Helsinki International Airport. Image: Lehtikuva

42. BS8300-1:2018, 10.11 Assistance dog toilets/ spending areas

43. Guide Dogs For The Blind Association, Guidance on the provision of spending facilities for guide dogs and other assistance dogs

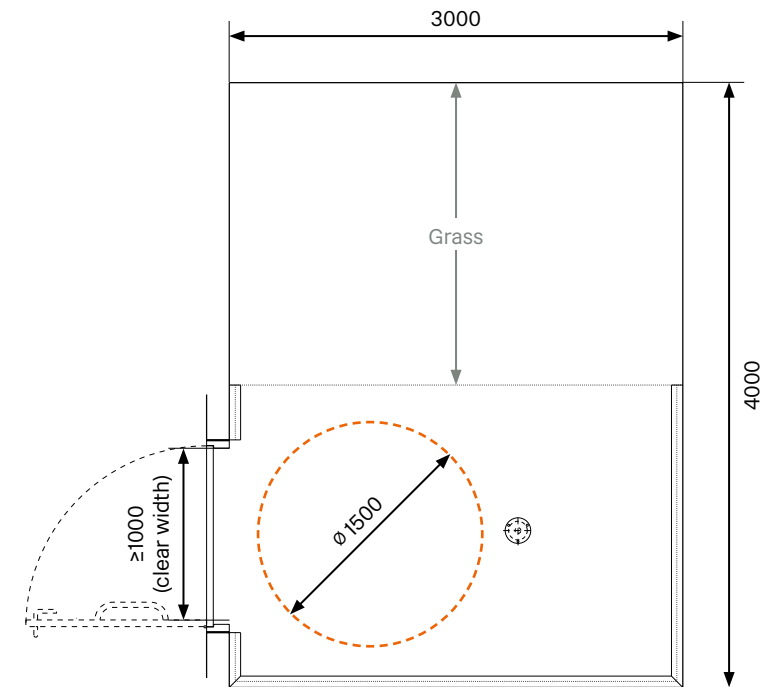



Fig. 37 - Example layout of assistance dog spending area

 Wheelchair turning space [Ø 1500]

Dimensions in millimetres

# Space Planning Guidance for Facilities

## 3.16 Attendant and Cleaner's Facilities

Station toilets will require different cleaning regimes dependent on usage, however, it should be assumed that a higher level of cleaning than has historically been provided will be required, due to increased usage following an upgrade of facilities.

### 3.16.1 Attendants

Toilet facilities in Network Rail's managed stations should have an attendant present whenever the facilities are open for public use. Attendants should be visible or easily contacted for people who require use of facilities with controlled access, e.g. Changing Places toilets.

Provision for attendants has historically been a room with a window facing the WC entrance. Removing this space can provide additional WC capacity, however, this should be considered against health and safety requirements for attendants in the station. If this space is omitted, a space for attendants to store their belongings and make hot

drinks should be provided elsewhere in the station.<sup>[44]</sup>

### 3.16.2 Cleaners

Cleaners should be provided with a lockable cleaner's store of minimum dimensions 2000 mm x 3500 mm, and a usable space (not impinged by door swings) of at least 4.5sqm. The store should include a cleaner's sink and provide adequate space for the storage of all supplies likely to be consumed in a day, with an assumption that larger quantities of supplies are stored elsewhere in the station.

It is preferable for the cleaner's store to have direct access to both male and female facilities as well as providing a route into service corridors where possible.

The importance of a high standard of cleanliness cannot be overstated and is the best way to prevent misuse and minimize the infection risks that unhygienic facilities present.<sup>[45]</sup>

### 3.16.3 Consultation

Where the contractor is known, attendants and cleaners should have a chance to give their views on any new toilet designs prior to approval by Network Rail. Attendants and cleaners may be able to offer advice on ease of cleaning and foresee potential problems.<sup>[46]</sup>

Attendants and cleaners should also be included in toilet management and liaison meetings so that they understand why certain things are required.<sup>[47]</sup>

Further guidance on the management of public WC's is available in BS6465-4:2010 Section 5: Management of toilet blocks.

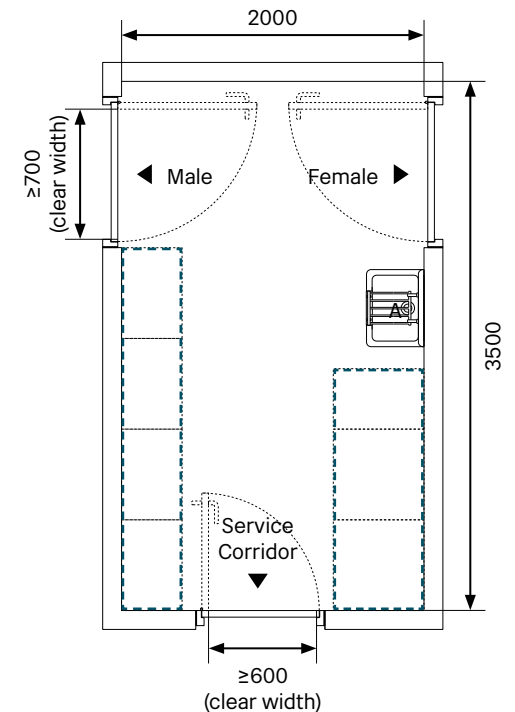



Fig. 38 - Example of cleaner's store with direct access to separate-sex facilities

 Storage [Varies]

A Cleaner's Sink [390 x 510]

Dimensions in millimetres

44. BS6465-4:2010, 19.4.1 Facilities for attendant

45. BS6465-4:2010, 21 Cleaning

46. BS6465-4:2010, 20.9 Management and staffing

47. BS6465-4:2010, 20.8 Management and staffing

Public Toilets In Managed Stations  
**Services Coordination**

4

# Services Coordination

## 4.1 Services Approach and Safety

### 4.1.1 Services Approach

A strategic approach to services, and corresponding access and maintenance should be considered from the outset, as excellent air quality, clear drainage and easy maintenance are fundamental parts of good design.

**Cosmetic upgrade of WC's will be insufficient to improve the customer experience without an effective services strategy. Services should be designed to minimise maintenance in public-facing areas so there is continuity in provision to users.**

All components should have an IP rating suitable for location and environmental conditions.

Hygienic and well-maintained toilets are less likely to be abused than toilets that are neglected, with ventilation significantly impacting customer satisfaction and perceptions of hygiene. Good air quality, drainage and maintenance in toilets presents an opportunity for WC's within managed stations to be clearly differentiated from other public toilets.

Sanitary appliances should have a clear services access route from behind (see overleaf), however, where public facing access panels are required for WC's and urinals an upper panel should be installed to provide cistern access. A lower panel should be fixed within the wall assembly that allows for removal of the appliance for longer term maintenance. All wall-mounted access panels should have tamper resistant fixings and be flush with wall finishes.

### 4.1.2 Safety and Security

**To safeguard safety and security, any removable elements (e.g. demountable ceilings and ventilation grilles) should either be avoided or made tamper resistant.** This is to prevent the concealment of weapons, drugs and other illegal items that pose a risk to staff and the public. For the same reason, ledges and horizontal surfaces above eye level should be avoided by using angled top panels (e.g. on top of vanity units or cubicle walls).

**CCTV should be used at the entrance to all facilities as a deterrent to antisocial behaviour.**<sup>[48]</sup> In locations

where anti-social behaviour and criminal activity is high, it is advantageous to include a public-facing CCTV monitor in the entrance area to act as a deterrent.

CCTV should also be used within separate-sex WC's where the privacy of users can be maintained, i.e. CCTV should not show the inside of any cubicle or urinal areas. Staff monitoring may be required in addition to CCTV (see pages 31, 36 for attendants). CCTV coverage should be in accordance with BS 7958.

Where waste/disposal bins are required in unisex and accessible facilities, these may need to be clear plastic bags suspended from plastic or metal hoops to meet station specific security requirements.



Angled panels atop cubicle walls prevents the concealment of illegal items, London Victoria WC's. Image: Peter Langdown



CCTV monitor in WC entrance at London Victoria. Image: Oliver Ansell

48. BS6465-4:2010, 15.6 Access to and circulation around the building

# Services Coordination

## 4.2 Service Corridors and Ceilings

### 4.2.1 Service Corridors

Wherever possible, sanitary appliances (WC pans and urinals) should have a clear services access route (non-public) to allow air extract, plumbing and maintenance to fittings from behind.<sup>[49]</sup> This enables WC's, urinals, and air extract to be incorporated without public-facing access panels which can present cleaning, maintenance and security issues.

Non-public services access routes (also referred to as services corridors) should have a minimum width of 600 mm (550 mm in a local condition) from protruding fittings and should be wide enough to allow easy access for maintenance, repair, and waste removal where applicable.

The location of doors into service corridors should be considered so that they do not open into pedestrian flows, and that they are not placed in a position where they may be misidentified as public access doors. It is preferable for service corridors to be accessed from

non-public areas, however, where doors to service corridors are public facing they should be marked with appropriate signage.

### 4.2.2 Ceilings

Demountable ceiling panels have significant disadvantages for concealing weapons, drugs and other illegal items, and should therefore be avoided.<sup>[50]</sup> A continuous ceiling finish is recommended with ceiling mounted services and equipment planned to minimise the need for access covers.

If smoke detection is required in ceiling voids, locating these within the services corridor avoids the need for access hatches, however, downstand beams need to be considered when locating smoke detectors.

Light fittings should be accessible and maintainable from below, and should include tamper resistant fittings where they may be within reach. Air supply valves should be in public circulation areas to discourage tampering.

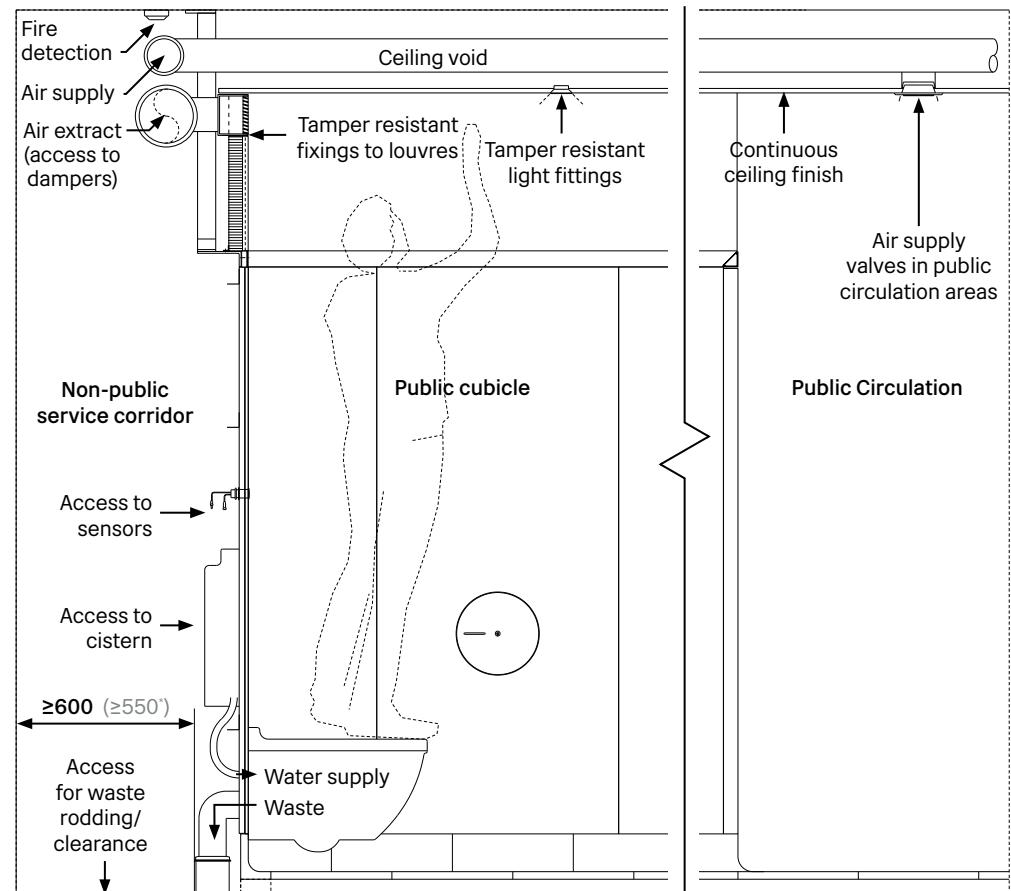

Fig. 39 - Primary services

Dimensions in millimetres

49. BS6465-4:2010, 19.7 Service corridors

50. BS6465-4:2010, 19.12.4 Ceilings



### 4.3.1 Drainage

Drainage distribution and access requirements will vary greatly for individual projects, however, full height cubicle partitions makes the coordination of floor access hatches particularly important (Fig. 41).

WC's in stations are in constant use, therefore WC refill times are critical, particularly in areas of low water pressure. Water supply and drainage system designs should take into account a scenario where all sanitary appliances are flushed/activated simultaneously. Designs should run to outfall to safeguard sufficient capacity.

All water pipes and tanks should be properly insulated to avoid freezing and avoid the risk of Legionella bacteria.<sup>[51]</sup> Where hot water is delivered, e.g. taps for wash troughs, water should be blended at the tap and delivered at no more than 41° Celsius.<sup>[52]</sup> Requirements for the design of water supply systems are given in BS 6700 and BS EN 806.

51. BS6465-4:2010, 19.13.1 Plumbing  
52. BS6465-4:2010, 19.3.9 Plumbing

### 4.3.2 Floor Access Hatches

Floor access hatch openings, structural and movement control joints should be coordinated with the floor tile grid. Joints should be in stainless steel or aluminium. Floor access hatches should be positioned in a manner that cut tiles are reduced to a minimum. Where required, visible seals and other joints are to be minimised and colour matched to the surrounding flooring.

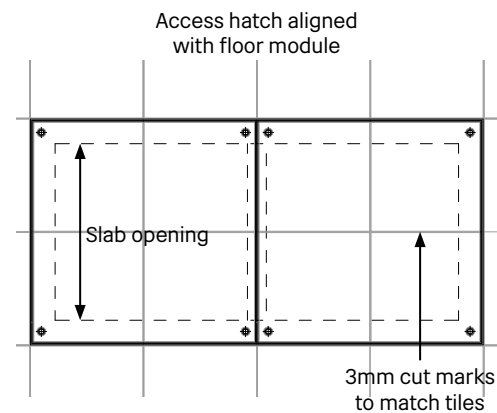

Fig. 40 - Floor access hatches

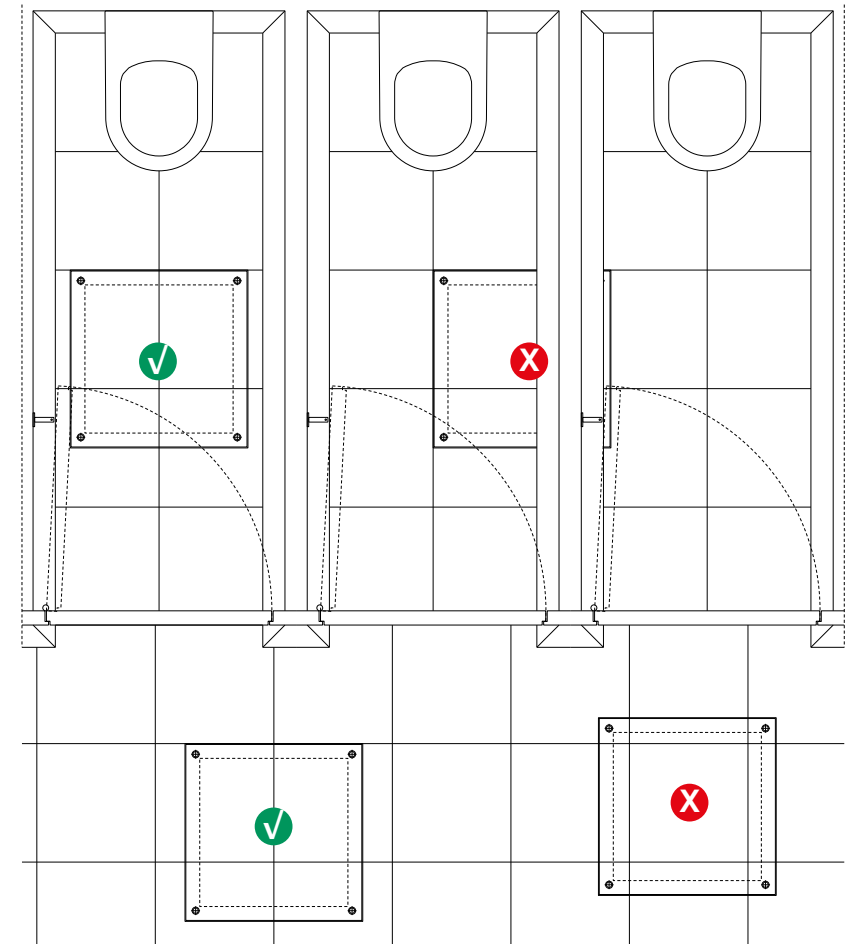

Fig. 41 - Floor access hatches

# Services Coordination

## 4.4 Wash Troughs and Vanity Units

Wash trough design should consider internal space requirements of components and services, in addition to durability and ease of access and maintenance.

**The area below the trough should be reserved for waste, supply and return water only, accessed from the front via locked access panels. Soap dispenser cartridges should be located within the vanity unit with power and pump coordinated with power for hand dryers.**

Taps and soap dispensers should be able to withstand considerable load, and should therefore be securely fixed from behind. Stainless steel reinforcing plates may need to be cast into the terrazzo trough where space behind the taps is restricted.

Further guidance on the materials and finishes to be used on wash troughs can be found in section 6.4.

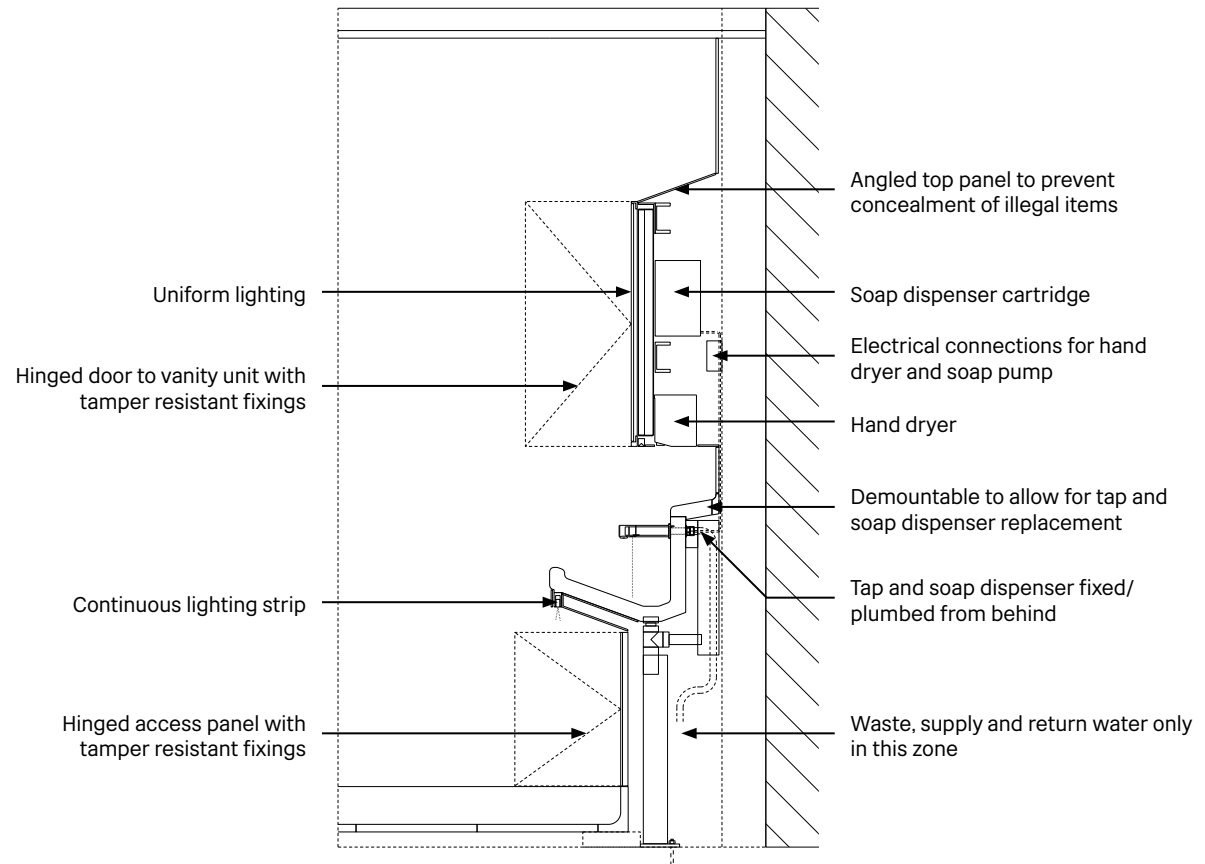

Fig. 42 - Wash Trough and Vanity Unit

# Services Coordination

## 4.5 Lighting

**Lighting should not only be used to maintain minimum luminance (100 lux at floor level), but to accentuate architectural features, assist intuitive wayfinding and improve the customer perception of WC's. Focal points such as primary circulation routes, stairs and wash troughs will require a higher level of illumination.**

Primary circulation routes including stairs should be illuminated using individual or paired vertical downlights. Illuminated handrails should be used to provide volumetric interest and a sense of invitation, particularly where WC's are located below street level.

Creative lighting designers should be consulted, as well designed lighting is key to enhancing the visual interest and texture of surfaces. For example, directional downlights should be used to highlight the exterior face of cubicle doors. Where directional downlights are planned. It should be noted that gimbal light fittings are not suitable for emergency use.

Light fittings should be easy to maintain, and have tamper resistant fittings

where there is a risk of misuse.

Every cubicle should be individually lit using vertical downlights and backlit light panels at high level (see section 3.2) where applicable.

Care should be taken to avoid lighting that may be perceived as unflattering by customers (e.g. overly fluorescent light that desaturates skin tones, or harsh downlighting that cast shadows on the face), so that customers feel more positive about themselves and their surrounding environment. Uniform infill lighting adjacent to mirrors on the vanity units is particularly helpful in this regard, in addition to providing additional illumination and a focal point around washing facilities.

Timed lighting systems should not be used in self-contained unisex facilities, as reactivating lighting may be difficult for those with mobility impairments.<sup>[53]</sup>

Diagram colours are for illustrative purposes only and are not indicative of colour temperatures.

53. BS8300-2:2018, 18.6 Changing Places Toilets

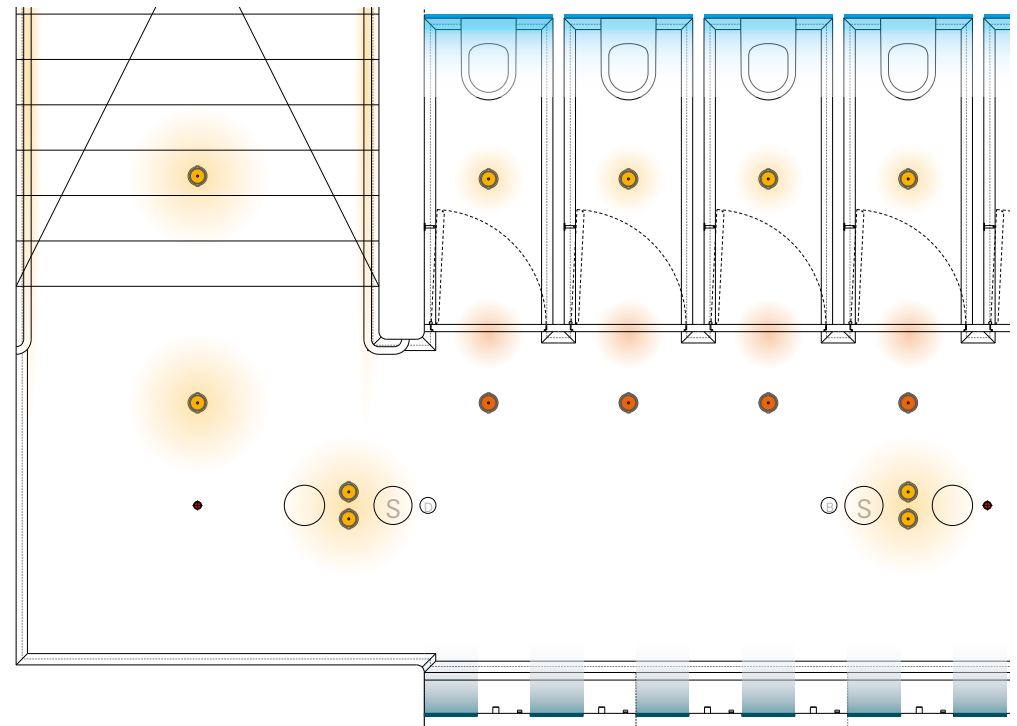







Fig. 43 - Example of lighting layout

- |   |  |   |                               |
|---|--|---|-------------------------------|
|  | Vertical downlight (primary circulation) |  | Uniform light panel (vanity)  |
|  | Vertical downlight (cubicle)             |  | Backlit light panel (cubicle) |
|  | Directional downlight (cubicle door)     |  | Emergency lighting            |

Public Toilets In Managed Stations  
**Wayfinding and Information**



# Wayfinding and Information

## 5.1 Wayfinding

**Wayfinding should encourage seamless and intuitive navigation within station environments. Wayfinding is not only concerned with signage, but with the architectural quality and intuitive layouts.**

The use of directional and identification signage, public announcements, location maps and the staff/customer interface should provide reassurance to passengers. The efficiency of any sign relies on the ability of users to detect, recognise and read the information conveyed.

Within the WC environment, layouts, continuity in materials, the use of natural and artificial lighting, the consistency of signage at key decision points, and the application of supergraphics should support intuitive wayfinding and simplify decision making for passengers. Progressive disclosure prevents an overload of information and reduces customer anxiety (see section 5.3).

Signed routes to all facilities should, wherever possible, be fully accessible. Where a barrier free route is not

possible, an alternative accessible route and facility should be highlighted as appropriate.

**Key wayfinding signage, such as toilet identification, should be clearly separated from other types of signage such as retail and advertising.** The image right shows the entrance to the WC's at Charing Cross station, where poor information hierarchy and an overload of signage types creates visual confusion, reducing the effectiveness of wayfinding.

### Standards Reference

Station Wayfinding design and assurance procedure  
NR/L2/CIV/150  
Wayfinding Design Guidance  
NR/GN/CIV/300/01



# Wayfinding and Information

## 5.2 NR Wayfinding Design Guidelines

Design Guidelines  
Managed Stations WC's  
NR/GN/CIV/200/04  
Issued: October 2020

46/72

Public facing signage fulfils an essential role in a station user's experience, and is the only common expression of the Network Rail brand across all managed stations. It is therefore key that signage is implemented and maintained in a consistent fashion.

**The Wayfinding Design Guidance (NR/GN/CIV/300/01) should be used in the design of passenger signing for Network Rail's managed stations.**



The guidance cover all public facing signs that provide directional and identification information to station users, and is to be used when planning signing for a new station, or when refurbishing a discrete station area, such as WC's.



Directional platform signage, London Bridge Station. Image: Oliver Ansell

# Wayfinding and Information

## 5.2 NR Wayfinding Design Guidelines (continued)

The standard signing typeface is 'Rail Alphabet 2'. This is the only font allowed on signs, and it should not be digitally altered in any way.<sup>[54]</sup>

Direction and location signs should use the terms 'accessible toilet', 'babycare', and 'toilets' only.<sup>[54]</sup> Localised signage that is not solely for direction and location purposes may use other wording such as 'Changing Places toilet'; however, all text is subject to approval by Network Rail.

Retail and advertising signage presents a potential conflict with wayfinding.

**Wayfinding signage should always take visual priority over other non-statutory signs, and its view should always remain unobstructed from the key intended reading directions.**

Wayfinding signage within the WC environment should be fixed at a consistent datum.

The built heritage of stations should be considered when specifying the siting

and fixing of signs in areas of historical and architectural value, such as listed buildings.

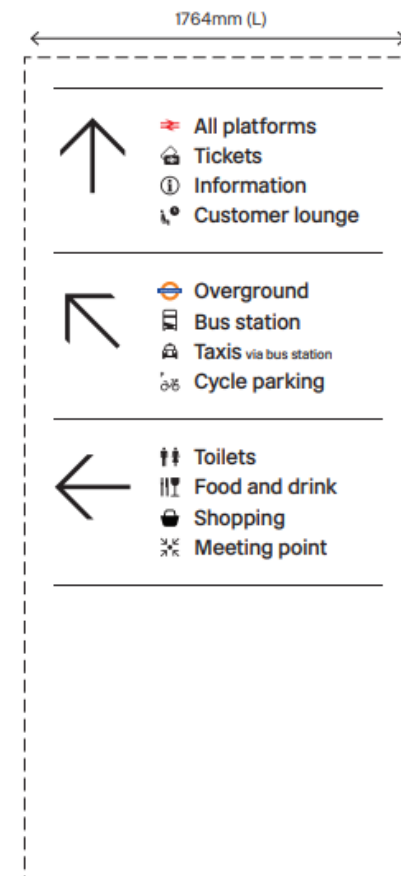

Height inconsistency and retail conflict compromises sign identification, London Paddington. Image: Network Rail



Clear space around signage with large pictograms describing full range of facilities available, London Victoria. Image: Oliver Ansell

# Wayfinding and Information

## 5.3 Progressive Disclosure

Progressive disclosure prevents an overload of information and reduces customer anxiety. The sequence shown is a guide only; signage requirements will vary at every station and wayfinding should consider more than just physical signage.

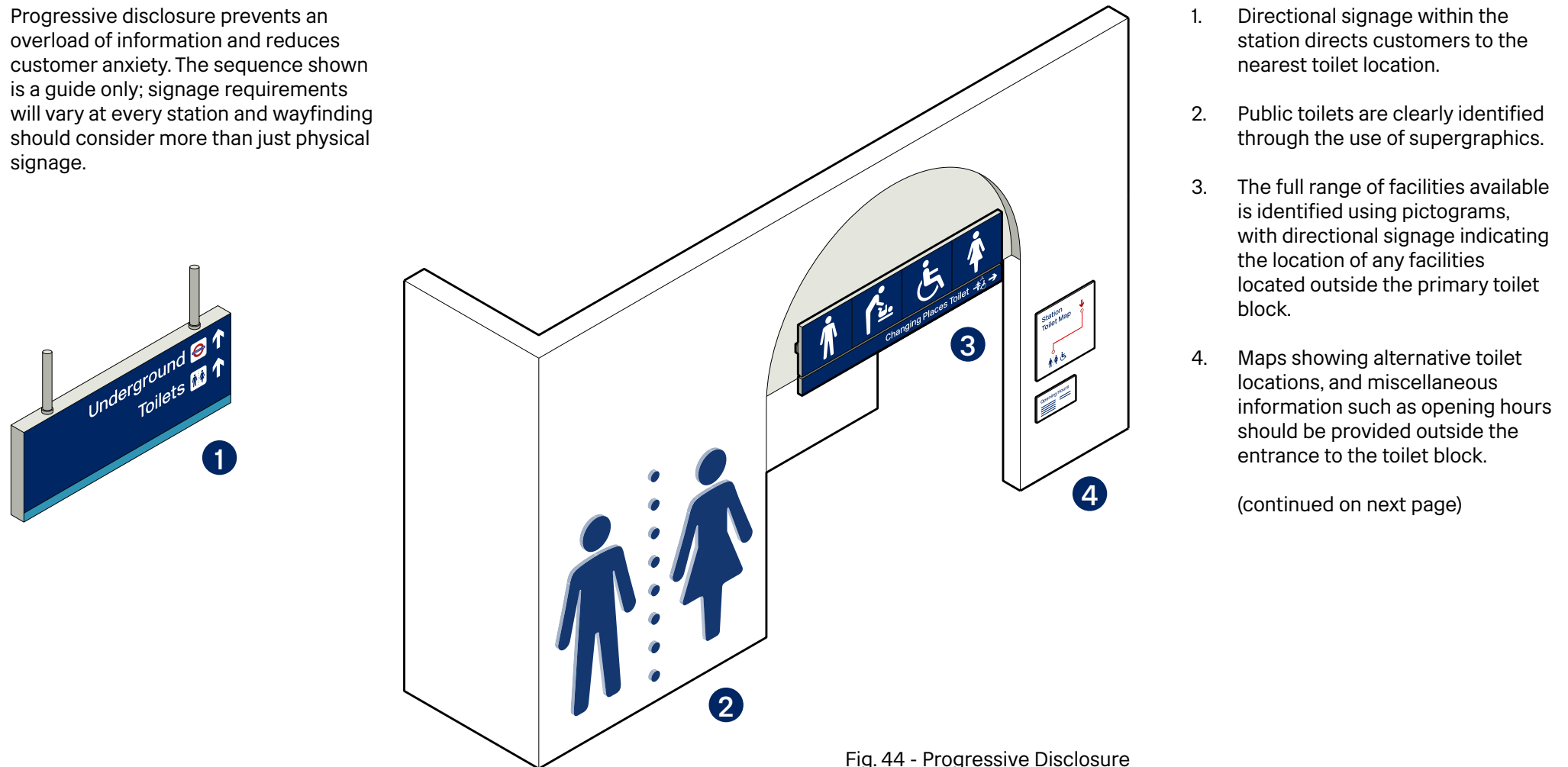
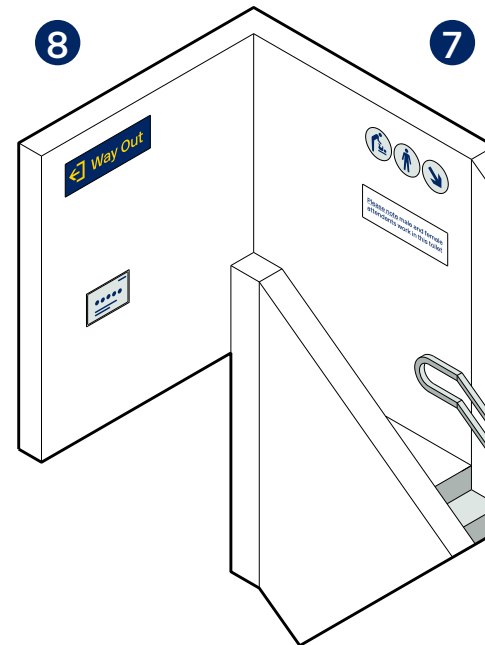
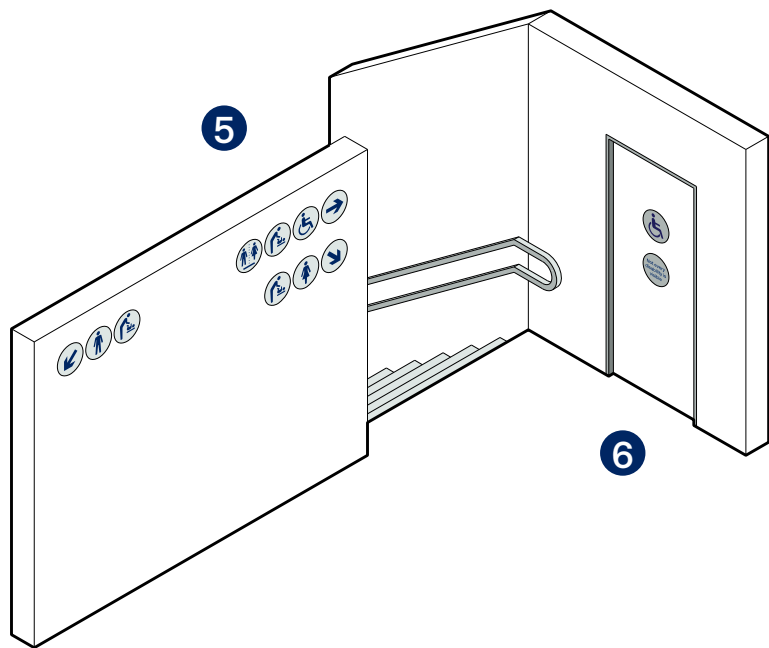

Fig. 44 - Progressive Disclosure



# Wayfinding and Information

## 5.3 Progressive Disclosure (continued)



5. Directional signage is used to show the location of facilities within the main toilet block.
6. Localised signage, e.g. on doors (see page 53), identifies the type of facility available.
7. Additional customer information, e.g. attendant signage (see page 55), is provided where necessary.
8. Directional signage indicates exits where required; options for customer feedback are provided.

The placement of additional customer information such as attendant signage and customer feedback screens should be carefully considered so as not to interfere with directional wayfinding for customers entering the toilets.

Fig. 45 - Progressive Disclosure

# Wayfinding and Information

## 5.4 Statutory Signs

**Statutory signs should be clearly separated from wayfinding, with escape route signs taking precedence over all other signs.**

Statutory signs differ from wayfinding signs in that they provide warnings, details of hazards, safety information and emergency procedures. Sign design, content, positioning and use should be compliant with BS5499-10:2006.

Where statutory signs conveying different messages are required within the same area a hierarchy of risk should be established and the safety signs prioritized accordingly. For example, fire equipment signs should not overwhelm escape route signs.<sup>[55]</sup>

Statutory signs conveying the same message within one area, e.g. escape route, should be of a consistent size and sited at a consistent height.

Escape route signs should be placed in WC areas so that a person moving within the means of escape is progressed towards a final exit.

**Statutory signage locations should be considered as early as possible, to allow for coordination with other fittings and fixtures, such as lighting, ventilation and emergency address systems.**

Statutory signs are project specific and should be designed accordingly.

Further guidance on the design of escape route signs can be found in BS5499-4:2013 Part 4: Code of practice for escape route signing.

Further guidance on the design of safety signs can be found in BS5499-10:2006 Part 10: Code of practice for the use of safety signs, including fire safety signs.



Fig. 46 Examples of an escape route sign, consisting of an emergency exit sign, directional arrow and supplementary text



Escape route sign coordinated with light fittings, London Victoria Station. Image: Wendy Hardie

55. BS 5499-10:2006, 4.8 Zones of Influence

# Wayfinding and Information

## 5.5 Pictograms

Pictograms (or sign symbols) should be displayed in accordance with Network Rail Sign Standards for use with Rail Alphabet 2. Where pictograms are unavailable from Network Rail, pictograms should conform with those shown in ISO 7001.

### Pictograms should be used on all directional and identification signs.

There is ongoing discussion within the industry surrounding the design of fully inclusive pictograms, such as an improved gender-neutral icon and icons that better reflect people with "invisible disabilities" such as those who are not in a wheelchair, whose condition cannot be seen, or is discrete. Any alternative designs will be subject to approval by Network Rail.

Adequate contrast between the symbol and its background is essential and the symbol should be given a sufficiently large surrounding area to make it legible.<sup>[56]</sup>

Pictograms should use RAL 240 30 35 blue and RAL 9016 Traffic white for either symbol or background.

Symbols should normally be used in a box, however, there are three exceptions to this rule when symbols should not be boxed (inverted):<sup>[57]</sup>

- When a sign consists of only one text line and no arrow;
- When a symbol stands alone, on a sign without text;
- When a symbol supports secondary text on a directional sign.

The pictograms shown on this page are illustrative only, design files are available from Network Rail.



Toilets



Accessible toilet



Gender-neutral toilets



Babycare



Ambulant accessible toilet



Changing Places toilet

Fig. 47 - Key pictograms

56. BS6465-4:2010, 16.4 Signage and Information

57. Managed Stations Wayfinding Design Guidelines and Specifications, March 2011, Pictograms (withdrawn)

# Wayfinding and Information

## 5.6 Supergraphics

Pictograms and text can be increased in scale to create **'supergraphics', visual beacons highlighting key functions of the station**, such as the location of toilets. They aid wayfinding and also create visual impact, and can be utilised to create moments of delight in station environments.

The 'toilets' pictogram, consisting of a male and female figure separated by a dotted line, should be used to indicate the location of public toilets, including separate-sex facilities and unisex facilities where applicable. Localised signage should then provide directional wayfinding for all facilities at relevant decision points. Pictograms should be in accordance with Network Rail Sign Standards.

Supergraphics should balance, scale, colour and contrast so that they are well integrated, whilst being prominent enough for people to navigate with confidence. Supergraphics should be considered within the station context, and are not appropriate for all environments.

Supergraphics can be backlit to provide a stronger visual beacon. This can be particularly useful in environments that do not receive natural daylight, and where artificially illuminated signage is particularly noticeable.

Where 'figures' are used in supergraphics, they should be at a scale greater than 1:1 so that they are prominent in crowded environments.

Where supergraphics are not flush with the wall, e.g. backlit signage mounted on an existing wall surface, particular consideration should be given to the durability of such signage, particularly supergraphics in entrance spaces which are likely to come into contact with heavy luggage, pushchairs and other hard objects.

Any patterns overlaid on supergraphics should be consistent with station manifestation. It is not recommended to install temporary supergraphics, an integrated and permanent execution of the graphic is preferred.



Proposed backlit figures supergraphic, London Victoria station. Image: Landolt + Brown



Proposed backlit figures supergraphic, London Bridge station. Image: Landolt + Brown

# Wayfinding and Information 5.7

## Unisex / Gender Neutral Facilities

**Unisex facilities should be correctly signed to make certain priority is given to customers who need these facilities most.** Wayfinding signage should include directional signage to unisex facilities, using the relevant pictograms for 'accessible toilets', 'ambulant toilets', 'babycare', 'gender neutral' and 'changing places' where relevant.

**Unisex facilities should be clearly identified with signage on doors, preferably no smaller than 200 mm in diameter.** Door signage should be etched stainless steel, with pictograms and text in 'Rail Alphabet 2' in RAL 9005 Process Black

Door signage should show multiple pictograms where appropriate, for example, a 'babycare' pictogram and 'accessible toilet' pictogram for an accessible baby-changing facility. Pictograms should be ordered to prioritise relevant users. For example, where a unisex toilet for people with ambulant mobility impairments is also used as the primary gender-neutral toilet, the 'ambulant toilets' pictogram

should be placed above the gender neutral pictogram.

**It is advantageous to provide door signage with the words 'Not every disability is visible', on a sign type consistent with other door signage.**

Text on signage should use 'Rail Alphabet 2' in RAL 9005 Process Black

Where a Changing Places toilet is located with other toilets, then the Changing Places symbol should be displayed alongside all the usual pictograms on wayfinding signage. It can be beneficial to include the words 'Changing Places toilet' on the door to the facility as the pictogram is less widely recognised.

Where applicable, information on the availability of baby changing, Changing Places facilities and other facilities should be also be shown on direction signs within the wider station environment.<sup>[58]</sup>

Where Changing Places toilets have controlled access, and where an attendant may not always be available, instructions on how to access the

facility should be provided on signage in close proximity to the facility.

Consideration should be given to signage for blind and partially sighted people. If braille signage is provided it should be easy to locate and should be integrated as part of a sensory or tactile trail provided to guide users to facilities.



Gender  
Neutral  
Toilet



Fig. 48 - Additional signage to be used on doors of relevant unisex and/or accessible facilities

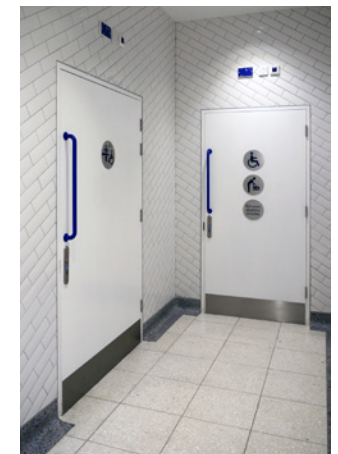

Stainless steel disc signage, London Victoria. Image: Abe Gordon

58. BS6465-4:2010, 16.3 Signage and Information

# Wayfinding and Information

## 5.8 Appliance Identification

All appliances should be identifiable, with signage using logical nomenclature. Appliances include, but are not limited to, WC's (signage to be on the outside of cubicles), urinals, taps and soap dispensers, and hand dryers.

**Appliance identification signage allows staff to identify particular appliances that may need maintenance, additional cleaning, or to be closed.**

As non-customer signage, appliance signage should be more discreet in appearance. Etched stainless steel discs are preferred, with finishes to match the surface to which they are applied. Discs should have a diameter of approximately 50 mm, or dimensions to match other fixtures in close proximity, e.g. door locks.

Cubicle identification should take the form of 'M/F xx', where 'xx' represents the appliance number, e.g. F01 for the first female cubicle.

Urinal identification should use the prefix 'U xx', where 'xx' represents the appliance number.

Taps, soap dispensers, and hand dryers should be identified either separately or together, using the prefix 'W xx' for wash trough, where 'xx' represents the appliance number.

Where appliance signage is used to identify urinals, consideration should be given as to whether signage is mounted on walls, privacy dividers, or the urinal itself. The least visually intrusive approach should be used. Where signage is mounted on privacy dividers, it should be clear as to which urinal is being described, particularly at the end of runs where a privacy divider may only be present on one side of a urinal.

Consideration should be given as to how WC's and urinals are identified from BOH service corridors. BOH signage should use the same logical nomenclature as signage in public areas.

Text on signage should use 'Rail Alphabet 2' in RAL 9005 Process Black' or RAL 240 30 35 /RAL 9016 Bright White, where black is not appropriate.

Text on appliance signage should be upper case with a minimum cap height of 14 mm to maintain legibility.

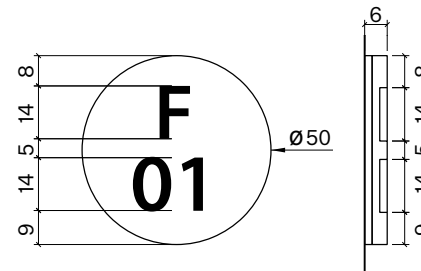

Fig. 49 - Recommended dimensions for appliance identification signage, dimensions in millimetres



The image above shows two options for the location of urinal identification signage, on privacy dividers (foreground), and below sensors (background). Image: Landolt + Brown



Cubicle identification signage, etched and PVD coated to match push plates, London Victoria. Image: Landolt + Brown. Signage to be mounted to push plate where practical.

# Wayfinding and Information

## 5.9 Additional Customer Information

Layouts should be designed to assist intuitive wayfinding and prevent queuing, however, in some instances additional customer information signage may be required to improve wayfinding within WC's. For example, where the full range of facilities available is not visible from the entry point to the WC's, directional signage should be provided to indicate the location of all facilities.

Particular consideration should be given to female WC's as an area where queuing is likely to occur. In the diagram right, queuing will occur at the entry point as people wait for cubicles in the two visible rows. Wayfinding signage should be added as indicated to show that additional cubicles are available despite not being visible.

In addition to wayfinding signage, designers should consider alternative methods that provide an overview of vacant cubicles. Doors should be hung to swing open when vacant, however, additional measures should be taken where practical to identify vacant cubicles to customers.

Additional signage may be used to direct customers to specific facilities within separate-sex WC's, such as baby changing cubicles or family toilets.

Text on signage should use 'Rail Alphabet 2' in RAL 9005 Process Black. Font size, leading and sign dimensions should comply with Network Rail guidance NR/GN/CIV/300/01

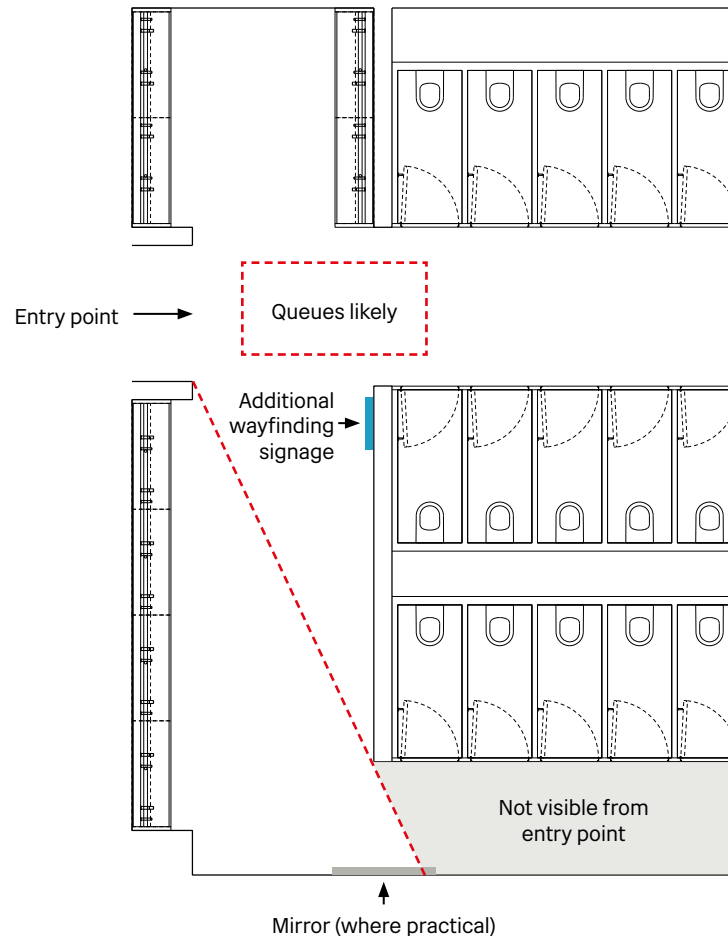

Fig. 50 - Example of layout where additional customer information signage will be required to indicate additional cubicles.

Additional x cubicles →

Additional x cubicles →

Fig. 51 - Examples of additional customer information signage, where 'x' denotes the number of cubicles.

# Wayfinding and Information

## 5.10 Attendant Signage and Customer Feedback

### 5.10.1 Attendant Signage

Where toilet attendants and cleaners are of the opposite sex to the users of the facility they are working in, a sign should be displayed at the entrance to the toilets advising users that an opposite sex attendant might be present within the toilets.<sup>[1]</sup>

The following text should be used in stations, **“Please note male and female attendants work in this toilet”**.

Text on signage should use ‘Rail Alphabet 2’ in RAL 9005 Process Black. Font size, leading and sign dimensions should comply with Network Rail standards.

Attendant signage should be coordinated with other signage in WC's. For example, the image (right) shows a proposed attendant sign of equal dimension to existing pictogram signs.

### 5.10.2 Customer Feedback

Signage should be provided displaying a telephone number, an e-mail address and/or a website, and a postal address so that users can give feedback and report any problems.<sup>[2]</sup>

The use of interactive digital displays to allow customers to give feedback is recommended. These displays typically have a scoring system indicative of the level of customer satisfaction. A function should be available that allows customers to leave detailed comments justifying their score.

All feedback is useful and can be used in multiple ways, such as informing cleaning schedules and alerting station staff to any issues.

At London Victoria, customer feedback showed that additional wayfinding signage was required in the female facilities notifying customers of the location of additional cubicles not visible from the facility entrance.

Certain issues will only become apparent during periods of significant use which cannot be tested prior to opening, reinforcing the importance of customer feedback.

The location of feedback displays should be carefully considered so as not to conflict with customer flows. Digital displays should be securely housed, provided with power and data, and have concealed or tamper resistant fixings.



Attendant signage within male toilets, London Victoria Station. Image: Landolt + Brown



Customer Feedback display, London Victoria station WC's. Image: Oliver Ansell

59. BS6465-4:2010, 20.3 Management and staffing

60. BS6465-4:2010, 20.12 Management and staffing



# Wayfinding and Information

## 5.11 Station Information

The location of public WC's should be shown on all station maps, with a key showing the different sorts of facility available in pictogram and text format. Where relevant the following facilities should be separately identified on maps: toilets (referring to separate-sex WC's), accessible toilets, baby care, toilets for people with ambulant mobility impairments, gender-neutral toilets and Changing Places toilets.

Where public toilets have been upgraded and there has been a change in the type of facility provided, station maps (both physical and digital) should be updated accordingly.

Where sanitary accommodation is located in more than one location within a station, a map should be produced showing the distribution and location of all public toilets within a station. These maps should include an appropriate 'You are here' symbol, and show a clearly identifiable step-

free route between locations with an approximate distance (shown in metres and in feet).

Maps and other similar signage should be permanent and integrated into the station architecture. Advice should be sought from Network Rail on the design of any new maps, taking into consideration existing maps and wayfinding within the station.

Following the installation of a Changing Places toilet, the facility should be registered with the Changing Places Consortium so that it can be added to the Changing Places map.<sup>[61]</sup> This is essential as the Changing Places map is the primary method by which people who require use of these facilities are able to locate them.

Signs giving the opening and closing times should be clearly displayed outside the toilets with directions to the nearest 24-hour toilet that is available to users if the toilet in question is closed.

[62]

61. Changing Places Consortium - After Installation, [http://www.changing-places.org/install\\_a\\_toilet/after\\_installation.aspx](http://www.changing-places.org/install_a_toilet/after_installation.aspx)

62. BS6465:4-2010, 16.6 Signage and information

### London Victoria Station toilet map

Alternative step free toilets are located on the eastern concourse alongside platform 2.

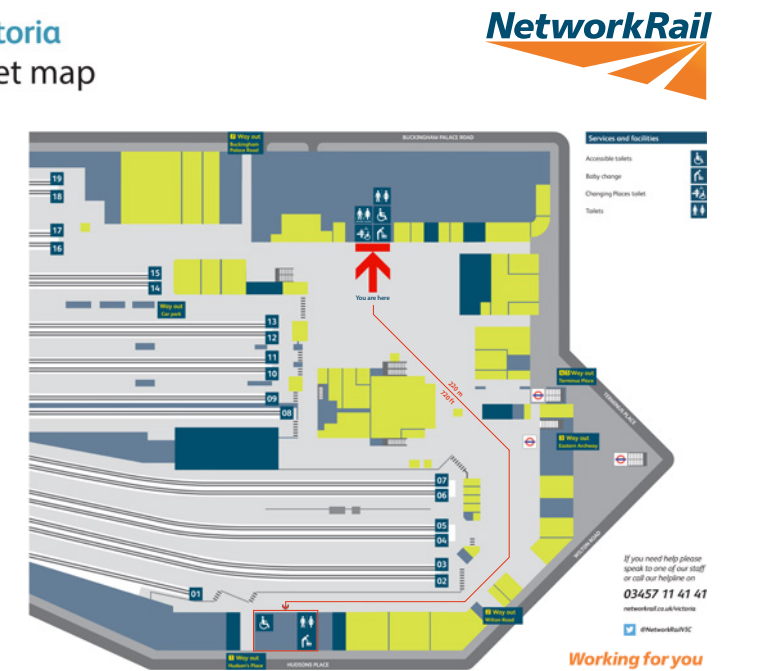

Fig. 52, Example of a station toilet map showing the location of alternative toilets at London Victoria. This diagram is for illustrative purposes only.

Public Toilets In Managed Stations  
**Materials, Fixtures, and Finishes**



# Materials, Fixtures, and Finishes

## 6.1 Sustainability

### 6.1.1 Environment

**As one of the countries largest asset owners Network Rail are obliged to embed sustainability into all projects. Network Rail Standard NR/L2/ENV/015 Environmental and Social Minimum Requirements mandates Network Rail's requirements for the management of environmental and social risks and opportunities.**

There is a requirement for Network Rail to register their schemes with Ska (the Royal Institute of Chartered Surveyors) environmental assessment method or the Building Research Establishment Environmental Assessment Methodology (BREEAM) Fit-Out and Refurbishment scheme so that tangible evidence based outputs are produced consistently.

Compliance with the standard delivers improved cost efficiency from sustainable practices such as waste minimisation and capital carbon evaluation.

Ska assessment is the mandated assessment tool for a toilet refurbishment (unless BREEAM is already in use to assess the project)

### 2.2.2 Ska

Ska comprises more than a hundred Good Practice Measures (GPM) covering:

- Energy and CO2 emissions
- Waste
- Water
- Materials
- Pollution
- Wellbeing

Each GPM is outlined in a data sheet explaining the criteria that need to be achieved. As each office fit-out project is unique, Ska rating only scores the project on GPMs that are relevant to the project.

Some measures are more important from a sustainability perspective, so the measures are ranked from 1 to 104, (1 is the highest and 104 the lowest). A project has to achieve a number of the highest ranked measures in order to score, known as gateway measures. The Ska assessment process is broken into three stages, with a certificate issued at completion of the project. Early engagement with the scheme should achieve the best outcomes.

NR schemes are to meet SKA Silver as a minimum requirement and Gold as an aspiration.



Ska	Score
Silver	> 50%
Gold	> 75%

### Standards Reference

Network Rail Environmental and Social  
Minimum Requirements

NR/L2/ENV/015

# Materials, Fixtures, and Finishes

## 6.1 Sanitaryware

Due to the wide variety of sanitaryware products are available the following functional guidelines should be adhered to when selecting products (within separate-sex WC's). Unisex facilities will have specific requirements as outlined in BS8300-2:2018. Products and suppliers previously used that meet the functional guidelines described can be found in Appendix C.

### WC Pans

- WC pans are to have a rimless flushing system to aid cleaning and improve hygiene
- WC pans are to be wall-hung to aid cleaning and maintenance
- WC pan seats should not have lids

### Urinals

- Waterless urinals should be avoided as they contribute to unpleasant odours, a significant aspect of passenger experience

### Wash Troughs

- Foam soap should be used, reducing the amount of product used and

- providing environmental benefits
- Water should be aerated to reduce water consumption
- All taps, soap dispensers and hand dryers should be sensor operated to aid those with mobility impairments, and provide cleaning benefits.

Foam soap dispensers require power and a pump within the tap or trough assembly. Additionally, the soap cartridges require a significant amount of space within the wash trough/vanity unit assembly which should be considered at an early stage of design as this may determine the dimensions of the overall unit.

Sanitaryware for unisex/accessible facilities should be compliant with BS8300-2:2018,



Examples of accessible and standard urinals (Duravit Starck 3). Images: Duravit

# Materials, Fixtures, and Finishes

## 6.2 Material Palette

The material palette for each station will vary dependent on the built heritage of the station, the location of WC's, as well as cost and programme constraints. The recommendations in Section F of this document are a guide only; projects should assess the appropriateness of materials on an individual basis.

**The material and colour palette within WC's should consider the heritage status of the existing station.** In general, warmer colours and materials (such as bronze and rose gold) may be more appropriate in sensitive and historic architectural environments, whereas monochromatic finishes and cool tones may be better suited to modern stations.

Particular consideration should be given to WC's that are located underground, or equally where ceiling heights are severely restricted. In such environments, materials should be used that alleviate the feeling of containment, utilising bright colours, reflective materials and planting where appropriate.

**Materials should be selected based**

**on a number of factors, included, but not limited to: appearance and customer experience, durability, ease of cleaning and maintenance, sustainability, construction feasibility, procurement, whole life cost, and capital cost.** All materials and their alternatives should be assessed against appropriate factors prior to selection.

The material and design decisions discussed in Section F are generally based on the successes and lessons learnt following the upgrade to WC's at London Victoria. Elements such as curved ends to wash troughs and PVD coated taps/soap dispensers, although functioning well, are not recommended for use in similar projects due to complexities in manufacture, with implications on cost and programme.

Walls in entrance areas and general circulation spaces should be tiled using a stretcher bond or similar to reflect the appearance of brick. Where WC's are accessed via stairs or split across multiple levels, diagonal tiles can provide a sense of direction and create a visual link between levels. Horizontal tiles should be used where WC's are at

concourse level.

At corners, curved wall tiles should be used to avoid the need for metal edge trims, creating a more monolithic and robust appearance.

White or pale coloured grout on walls and floors should be avoided as this will discolour quickly and unevenly. In addition, floor tiles should not be overly pale in colour, allowing them to obscure some dirt and wear within high traffic environments.



Material palette: terrazzo, back-painted glass, ceramic, stainless steel. Image: Landolt + Brown

# Materials, Fixtures, and Finishes

## 6.3 Cubicles

**Internal cubicle walls should be clad with back-painted glass;** colours and tone to be coordinated with other materials within WC's. It is preferable to use low-iron glass, except where the green tint of non low-iron glass is part of a coordinated colour palette.

**The internal cubicle wall visible when the door is ajar should be a distinctive colour so that vacant cubicles are clearly visible.** Back-painted glass should be durable enough to withstand impacts from items such as hard luggage. A satin finish to the glass is preferred, however, this should be considered against cost implications.

**Door leaves and cubicle trims should be of the same base material (e.g. stainless steel), however, the doors should vary in finish from trims.** For example, where brushed stainless steel is used, door should be of a light colour with a horizontal grain, with trims in a darker colour with grain to follow length of panels. PVD coated stainless steel is recommended to add variation in colour and/or tone. Anti-fingerprint coatings should be considered, particularly for door leaves and push plates where applicable.

Push plates (where used) should match the cubicle trims, with a vertical grain to follow the length of the push plate. Fixtures to the external face of the door (such as door locks and appliance identification signage) should be of the same material as push plates.

It is advantageous to provide an additional coloured strip to the edge of the cubicle frame, visible only when doors are ajar/open so that vacant cubicles are clearly indicated.

Where glass dividers are used above 2000 mm (see page 21), the colour of the glass should be coordinated with other materials within WC's.

Where backlit light panels are used on the rear wall of cubicles, these should not be coloured; the colour temperature of the light should be coordinated with other lighting within WC's.

Colours shown are for diagrammatic purposes only.

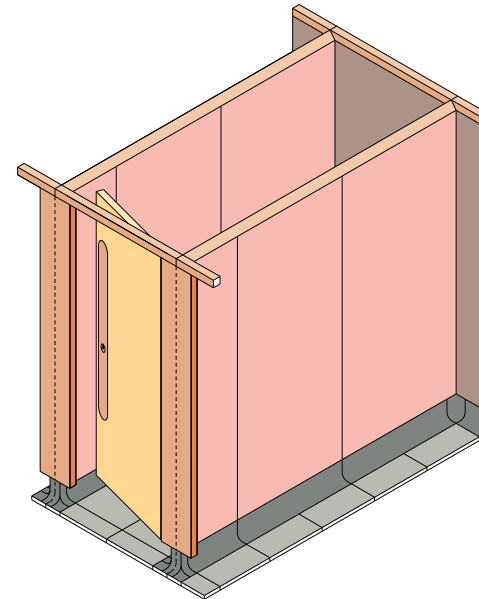

Fig. 53 - Primary cubicle materials

- Door Leaf Finish
- Trim/Push Plate Finish
- Coloured Strip
- Back-painted glass colours
- Terrazzo floor tiles
- Terrazzo skirting



Bronze and rose gold PVD coated stainless steel, with pink back painted glass creates a 'warm' overall aesthetic. Materials and finishes within London Victoria WC's by Landolt + Brown in collaboration with artist Wendy Hardie. Image: Peter Langdown



Edited image of London Victoria WC's to show material finishes and a colour palette appropriate for use in a contemporary station environment, e.g. London Bridge. Image: Landolt + Brown (edited), Peter Langdown (original).

# Materials, Fixtures, and Finishes

## 6.4 Wash Troughs

Wash troughs should be used instead of wash basins as they provide a single point of amenity, reducing spills and allowing for customer flexibility. Wash trough should consist of repeating units, with standard rim heights of 850 mm and minimum width of 700 mm. Guidance on space planning for wash troughs can be found in Section 3.8 of this document.

**The preferred wash trough material is terrazzo.** In certain instances acrylic based alternatives may be acceptable, however, resistance to dyes and burning should be considered. Stainless steel should be avoided as it has an overly utilitarian appearance. Where white wall tiles are used, light coloured troughs are preferred as this creates a more monolithic appearance, uniting the wash trough with the wall.

Wash trough runs should finish flush against a wall, curved end-pieces are not recommended due to costs associated with manufacturing. Where a wash trough run falls short of a wall, a shelf at rim height should be used at the end of the run. Wash troughs should be resin grouted, with the exception of the top panels which should be

demountable to replace taps/soap dispensers.

Metal trims of the vanity unit and wash trough should be coordinated (PVD coated stainless steel is preferred). The panels beneath the wash trough should be either terrazzo or the same metal as used for trims, and should be of a suitable thickness to make it durable. Where a brushed finish is used, the grain should follow the length of a panel.

Access panels beneath the trough should be glass, coloured to match the appearance of the terrazzo (e.g. white back painted glass).

Washing hands in a public toilet often includes touching several surfaces such as taps and doors that could transmit bacterial infection. The specification of copper alloy rather than stainless steel may be used to inhibit the spread of bacteria. Specifying sensor controlled mixer taps and soap dispensers should limit personal contact with surfaces.

Foam soap is recommended, however, the space demands for soap cartridges should be considered in the design of the framing.

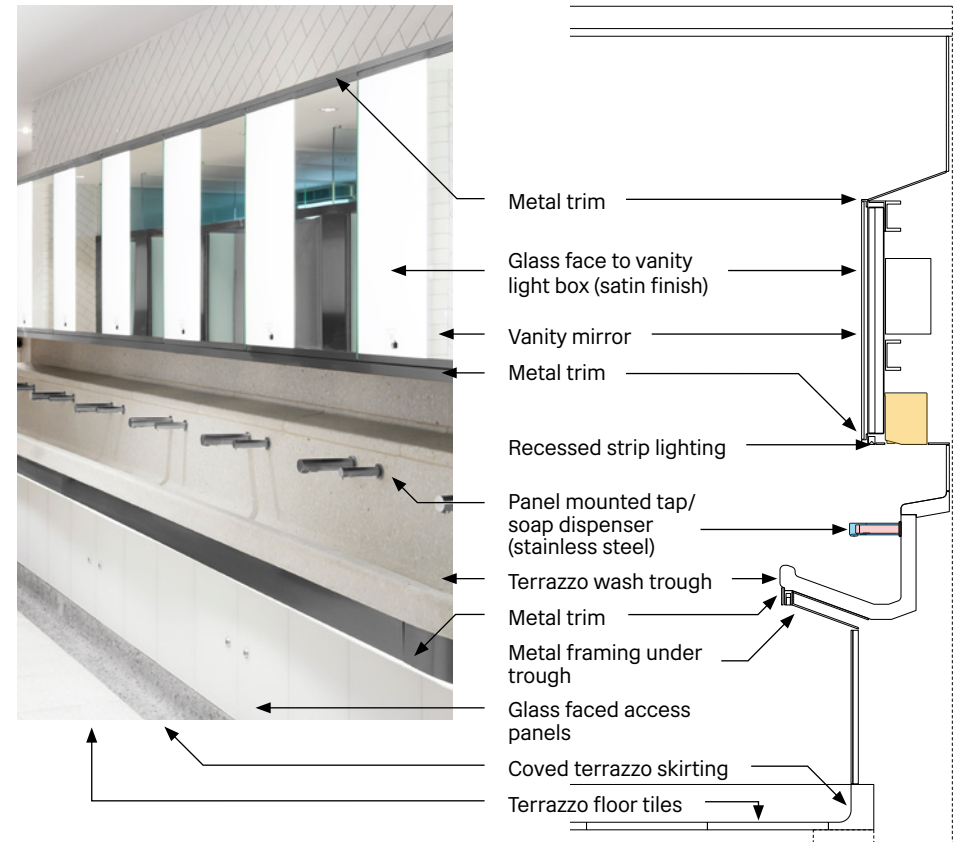

Wash troughs (edited), London Victoria Station. Image: Landolt + Brown (edited), Original: Peter Langdown

Fig. 53 - Wash Trough Section

- Hand dryer
- Tap
- Soap Dispenser

# Materials, Fixtures, and Finishes

## 6.5 Flooring

**Cementitious terrazzo tiles should be used in all WC's; tiles should be pre-ground where possible.** Within this constraint, individual projects should customise aggregate and colour composition to allow for contextual design integration.

Terrazzo is already heavily utilised in transport environments because of its intense durability (resistant to impact, fire, abrasion and wheeled traffic), ease of maintenance, and design life of 40+ years. There also exist manifold options for types of aggregate allowing for variations in finishes that create additional opportunity for designers to integrate contextual responses.

**Network Rail guidance, requires all floor surface materials to achieve a minimum target rating of 40 SRV (slip resistance value) on the pendulum test when the material is both wet and dry.** <sup>[63]</sup> Slip resistance

63. *Network Rail, Guidance on the planning and management of station flooring to public areas, January 2015, BLDG-SP80-001.*

64. *Department for Transport, and Transport Scotland, "Design Standard for Accessible Railway Stations", Version 04, March 2015*

will vary in environments such as toilets where the floor may be wet, therefore consideration should be given to the cleaning and care regimes required.

As slip resistance will also vary seasonally and according to patterns of wear (such as desire lines of pedestrian movement), **terrazzo should incorporate additives such as Silicon Carbide (Carborundum), Aluminium Oxide or Flint so that tiles exhibit differential wear.** Incorporating such additives within tiles enables the abrasive powder to be distributed through the depth of the tile's decorative surface which, once ground, exposes the grains enhancing the material's slip resistance.

<sup>[64]</sup> The size of aggregates should be limited to 9-12 mm to achieve slip resistance.

High contrast between aggregates in terrazzo flooring can be disorienting for visually impaired customers, therefore, low-contrast larger aggregates are preferred.

In addition to slip resistance and durability, terrazzo should be used in rail environments as it is non-combustible

(Class A1) and does not contribute to fire. Terrazzo tiles do not give off dangerous fumes if exposed to extreme high temperatures in fire conditions. Cementitious terrazzo is compliant with London Underground Engineering Standard E1402 'Fire Safety Performance of Materials'.

Pre-ground tiles avoids the need for post grinding on site and they can be calibrated to accommodate a reduced site depth as well as loading weights. These tiles can be factory sealed and have programme benefits as they can be brought into use within 2-3 hours after installation.

Although terrazzo is a very durable material, it is still stain sensitive and may require sealing with an appropriate 'impregnator' to protect against water, oil, dirt and other contaminants. Terrazzo should be sealed correctly prior to use, to warrant ease of maintenance and cleaning, maximising the lifespan of the material.

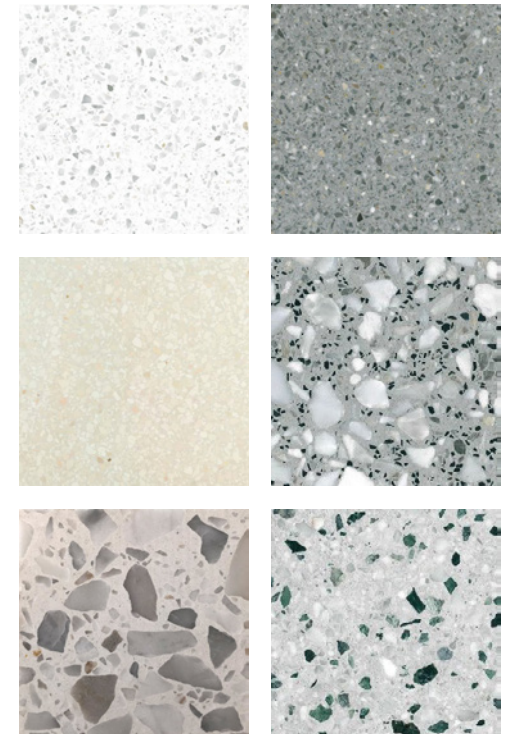

Terrazzo samples show the different appearances that can be created through varying aggregate composition and the colour of cement. Images: Diespeker & Co.



# Materials, Fixtures, and Finishes

## 6.5 Flooring (continued)

**A square tile module should be used across all flooring within WC's.** Typical module sizes include 300 mm x 300 mm, and 400 mm x 400 mm (preferred). Grout should be 3 mm, giving tile sizes of 297 mm x 297 mm, and 397 mm x 397 mm respectively. Within cubicles, tiles should be set out from the rear wall, and should be cut at the cubicle boundary. Module sizes should be designed to minimise wastage wherever possible.

**Coved skirtings allow for easier cleaning and should be used in all instances.** Coved skirtings should be terrazzo, although the appearance of skirting should be varied from that of floor tiles. There should be a minimum 30 point difference in LRV (light reflectance value) between the floor and skirting, as well as between the skirting and vertical wall surface. Coved skirtings should have a radius of between 40 mm - 50 mm, and be consistent throughout.

It is recommended to add movement joints every 6 m in each direction. In certain instances, where movement joints are misaligned, slip membranes should be introduced to transfer loads

to the misplaced movement joints.

The method by which terrazzo tiles are bonded to the screed bed will affect the lifespan of the tile. Bonding methods may vary depending on site conditions, however, a fully bonded tile is recommended for terrazzo laid in rail environments as it enables longevity and structural integrity. The total nominal floor build up including the cement bed is typically 72-80mm (cement bed approx. 40mm, tile 32-40mm).

Alternative flooring materials such as ceramic, porcelain and granite should only be used in exceptional circumstances where the use of terrazzo is not possible (for example where an extremely limited floor to ceiling height does not allow for the height of the build up associated with terrazzo tiles). Alternative flooring materials should comply with the same requirements for slip resistance, combustibility and visual contrast, and should be set out to a 400 mm grid.



Terrazzo floor tiles (400 mm x 400mm module) with drainage point, access hatches, and contrasting coved skirting. London Victoria WC's. Image: Peter Langdown

# Materials, Fixtures, and Finishes

## 6.6 Air Quality and Lighting

### Air Quality

Air quality is a significant contributor to customer perceptions of hygiene and cleanliness. Mechanical ventilation will be required to ventilate WC's, however, natural ventilation should also be utilised wherever practical.

The integration of air fresheners should be considered, however, air fresheners should not be used as a substitute for proper ventilation and cleaning.

Air supply and extract valves should be coordinated with other services, such as lighting, speakers and fire detection.



Coordinated services - London Victoria WC's.  
Image: Peter Langdown

### Lighting

Wherever possible, natural lighting should be used to illuminate the interior of WC's, including cubicles, through the use of high-level windows or roof-lights. As most WC's within stations will not be able to utilise natural daylight, it is crucial that artificial lighting is well designed to enhance the customer perception of WC's.

Lighting design is a crucial aspect of the architectural design within WC's and should be more than meeting minimum requirements for levels of luminance; specialist lighting designers should be consulted. Lighting can enhance or diminish the appearance of materials, finishes and people, and should therefore be designed to make customers feel positive about themselves and their surroundings.

In addition to meeting functional requirements, the colour temperature of lighting should be considered in conjunction with the material palette within WC's.

Guidance on the coordination and placement of lighting can be found in section 4.5. Lighting should be used to aid intuitive wayfinding, clearly illuminating primary circulation routes and entry/exit points to WC's.

Additional lighting should be used to illuminate specific activity areas, such as hand-washing/drying which can be illuminated using strip lighting within the vanity unit (see section 6.4).

Energy efficient light fittings should be used to help to minimize the use of electricity.

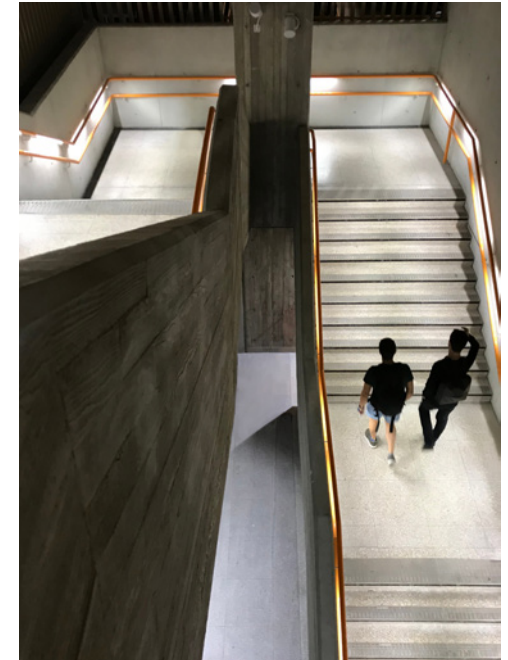

Illuminated handrails accentuate spatial contrast at Hackney Wick Station. Image: Adam Brown

# Materials, Fixtures, and Finishes

## 6.7 Planting

**Enriching interior spaces with greenery has been shown to increase customer perception on air quality and hygiene levels, as well as overall customer satisfaction with a space.**

<sup>[65]</sup> The appearance of well maintained planting positively reflects on the station environment and management, with customers associating well-maintained planting with well-maintained WC's.

Planting and greenery should be provided within WC's where there is reasonable space to do so. Planting should be located so that it is visible to as many customers as possible. The addition of planting 'brings the outside in', connecting the self-contained toilet areas with the wider external environment.

Where planting is installed it is important that staff adhere to a maintenance and watering regime, replacing any decaying plants for a consistent positive customer perception.

**Planting will should be protected and placed behind glass, with access provided for maintenance and cleaning staff.**

The type of vegetation placed in WC environments should be carefully considered, particularly in underground environments where natural daylight is limited. Where planting is used within internal environments, designers should seek specialist horticultural advice.

Green walls may provide a less space intensive solution to indoor planting, however, space saving benefits should be considered against the increased wall build-up required, drainage requirements, increased maintenance and the risk of damage and misuse within a heavily trafficked environment.

Lighting strategies should accentuate the colour and appearance of greenery, and consider the requirements of planting, particularly where natural daylight is unavailable. Additional blue wavelength light may be required to encourage foliage growth.

It is not recommended to use artificial planting in WC's as this compromises the appearance of the 'plants' in addition to the overall WC environment. Artificial plants composed of synthetic materials have a negative environmental impact, and are not easily biodegradable, whereas living plants have environmental advantages. The benefits to customer experience are severely limited where artificial plants are used; **projects with a 'customer first' approach should not use artificial planting.**

Where appropriate, the installation and curation of planting may form part of an artist programme or commission.

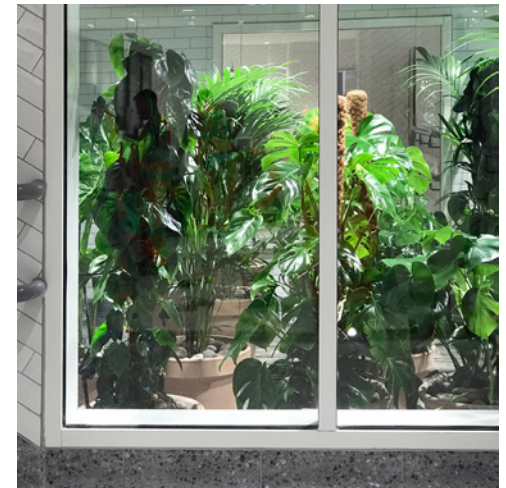

Planting within Victoria Station WC's. Image: Wendy Hardie



Planting within Singapore Changi Airport. Image: Mark Miller. Note that all planting to be behind glass in stations.

65. Nieuwenhuis, M., Knight, C., Postmes, T., & Haslam, S. A. (2014). *The relative benefits of green versus lean office space.* <https://psycnet.apa.org/record/2014-30837-001>

Public Toilets In Managed Stations  
**Appendices**

# Appendix A

## Relevant Standards and Guidance

Designs which claim compliance with relevant standards are expected to be able to justify any course of action that deviates from recommendations.

For dated references, only the edition cited applies. For undated references, the latest edition of the referenced document (including any amendments) applies.

Definitions of terms referred to in this document can be found in Clause 3 of BS6465-4:2010, and Clause 3 of BS8300-2:2018.

The following list is provided for reference only and is not exhaustive.

### Relevant Standards and Guidance

BS6465-1:2006	Sanitary installations – Part 1: Code of practice for the design of sanitary facilities and scales of provision of sanitary and associated appliances
BS6465-2:2017	Sanitary installations – Part 2: Code of practice - Space recommendations
BS6465-3:2006	Sanitary installations – Part 3: Code of practice for the selection, installation and maintenance of sanitary and associated appliances
BS6465-4:2010	Sanitary installations - Part 4: Code of practice for the provision of public toilets
BS8300-1:2018	Design of an accessible and inclusive built environment - Part 1: External environments - Code of practice
BS8300-2:2018	Design of an accessible and inclusive built environment - Part 2: Buildings - Code of practice
BS 9999:2008	Code of practice for fire safety in the design, management and use of buildings

Building Regulations (England and Wales) Approved Documents

Equality Act

Design Standards for Accessible Railway Stations, Version 04, Department for Transport and Transport Scotland, March 2015

PRM TSI, Persons with Reduced Mobility -Technical Specification for Interoperability

Scottish Building Standards, Technical Handbook Non Domestic (2013)

ISO 7001:2007 Graphical symbols – Public information symbols

Station Design Principles for Network Rail, BLDG-SP80-002, 2015 (superseded)

NR/L2/CIV/003 Engineering and Architectural Assurance of Building and Civil Engineering Works

NR/GN/CIV/300/01 Network Rail Wayfinding Design Guidance

NR/L2/CIV/150 Station Wayfinding design and assurance procedure

Network Rail, Guidance on the planning and management of station flooring to public areas, January 2015, BLDG-SP80-001.

# Appendix B

## Acknowledgements

This document was developed by  
**Landolt + Brown** for Network Rail.

### Image Copyright and References

All imagery shown in these guidelines are low resolution examples used for internal and illustrative purposes only. Copyright remains strictly the property of the originators. Under no circumstances should any of these images be used in external communications without first seeking permission from the originators. Should you wish to commission any of these images for use in external communications, you should secure the appropriate license.

#### **Louis Hellman**

12 ("*Queuing for the ladies*", cartoon first published in *Access by Design*, 1992)

#### **Peter Langdown**

9, 22, 28, 39 (Cubicles), 61, 62, 64, 65

#### **Landolt + Brown**

52, 54, 56 (Signage), 60, 61, 62

#### **Oliver Ansell**

38 (CCTV), 44, 45, 46, 55 (Feedack)

#### **Network Rail**

5 (Tile), 5 (Manchester Victoria), 46 (Paddington)

#### **Wendy Hardie**

49, 66 (London Victoria)

#### **Marissa V, Flickr**

4 (The Barbican)

#### **Mike Nettleship**

4 (Rothesay Pier)

#### **Rory Gardiner**

4 (V&A)

#### **London Less Travelled, Flickr**

5 (South End Green)

#### **Benedict O'Looney Architects**

5 (Peckham)

#### **RADAR**

18

#### **Lehtikuva**

36

#### **Abe Gordon**

53

#### **Duravit**

59

#### **Diespeker & Co.**

63

#### **Adam Brown**

65

#### **Mark Miller**

66 (Singapore)

# Appendix C

## Supplier References

A list of relevant suppliers is provided for ease of reference. The following list contains typical suppliers and products that have met previous project requirements and specifications.

The following list is provided for reference only and is not exhaustive, alternative products are available that meet project requirements and specifications.

### Suppliers

#### Andrew Tiles

Terrazzo wash troughs

#### Armitage Shanks

Sanitaryware for use in unisex facilities

#### Craven Dunnill

Ceramic wall tiles

#### DMC Contracts

Flooring, terrazzo

#### Dolphin Solutions

Taps, soap dispensers, toilet roll holders, coat hooks

#### Duravit

WC pans, urinals, privacy dividers

- Duravit Starck 3 Toilet wall mounted Duravit rimless, with Starck 3 toilet seat ring (to be fixed with anti-tamper screws)
- Duravit Starck 3 Urinals, 330 x 350 mm (Ambulant and Wheelchair Accessible)
- Duravit Starck 3 Urinals, 245 x 300 mm (Standard and Child)
- Duravit Starck 3 Ceramic Urinal Partition 705 x 400 mm

#### Geberit

Sensors, flush systems

#### Maxwood Washrooms

Cubicle assembly

#### Merson Group

Signage

#### Quiligotti

Flooring, terrazzo

#### TiGlass

Glass walls, doors, and panels

# 2000/04